

## Component layouts

The component layouts are shown in A3 format in the schematics section.

### ■ Component layout (top side), 1maa\_02

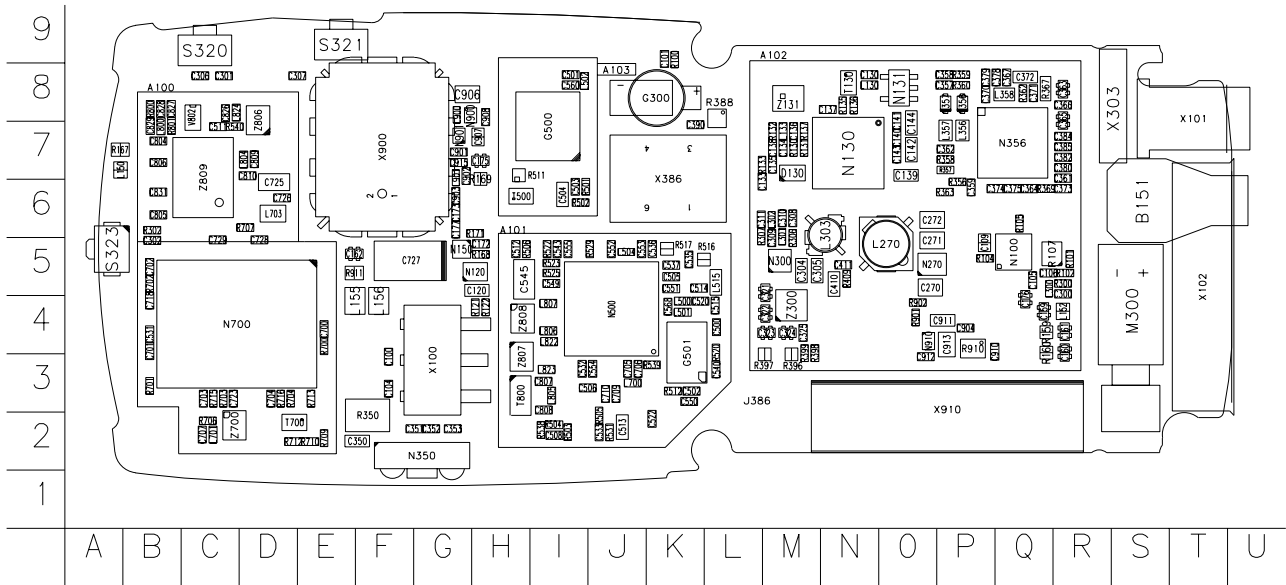

### ■ Component layout (bottom side), 1maa\_02

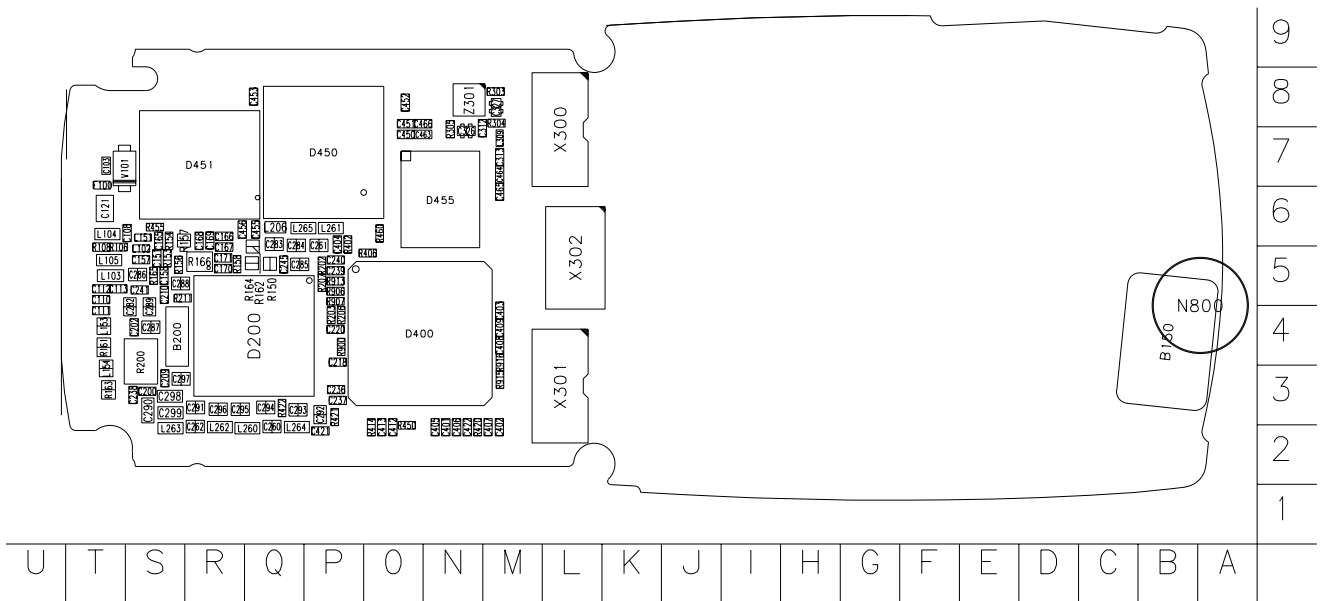

Top Level, 1maa\_02, v.0 ed. 40

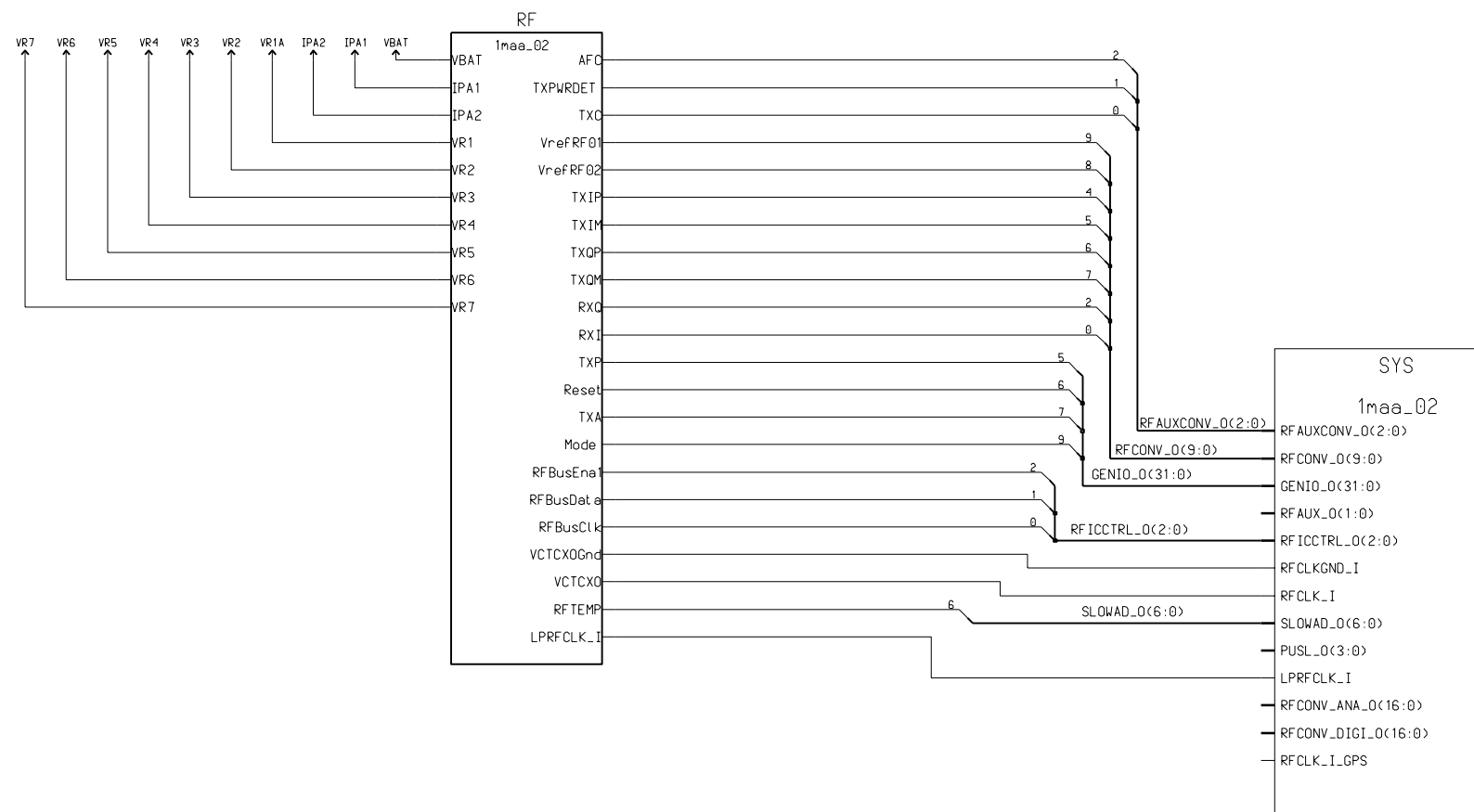

RF Top Level,1maa\_02, v. 0.0 ed. 67

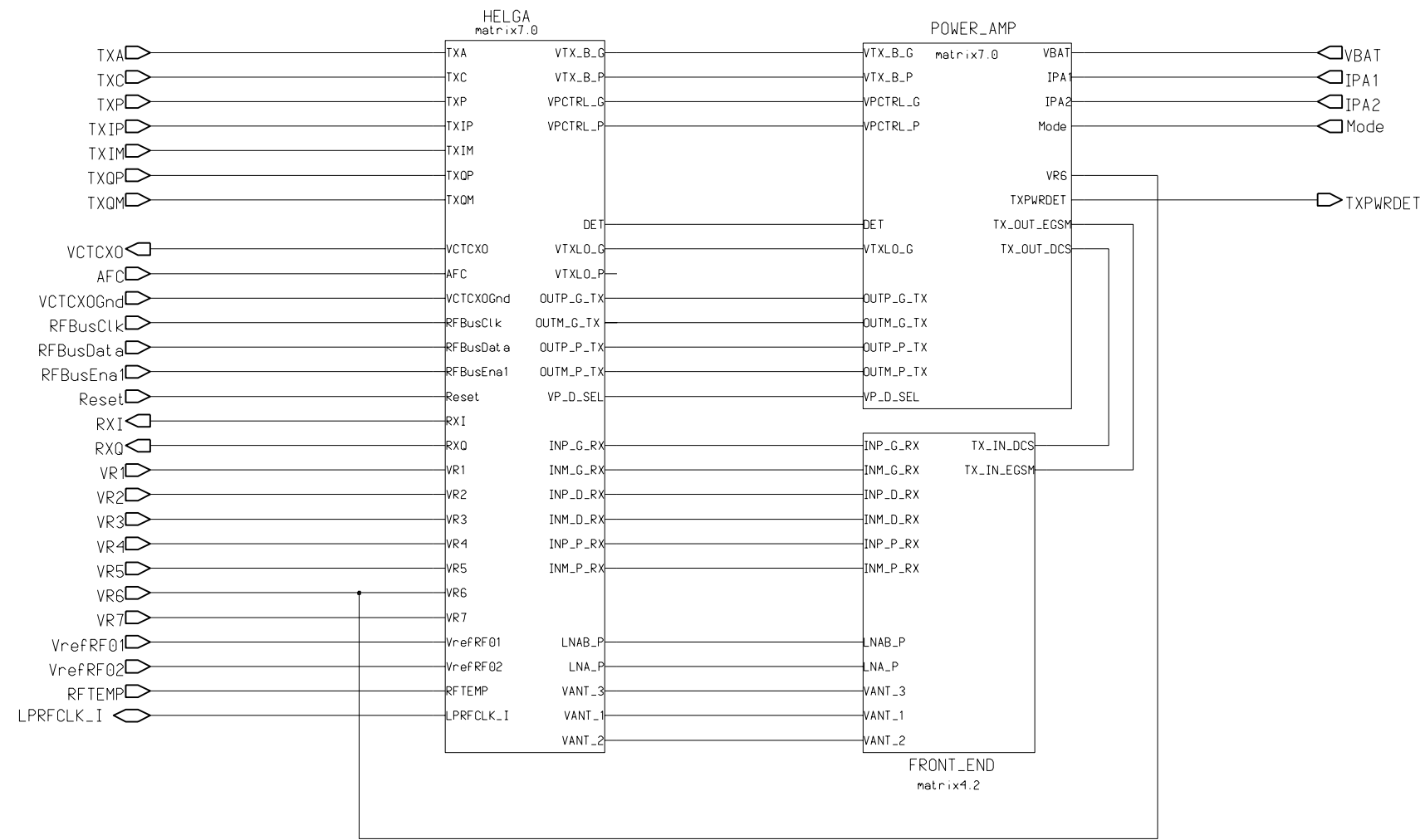

RX Front End and Antenna Switch, 1maa\_02, v. 0.0 ed. 79

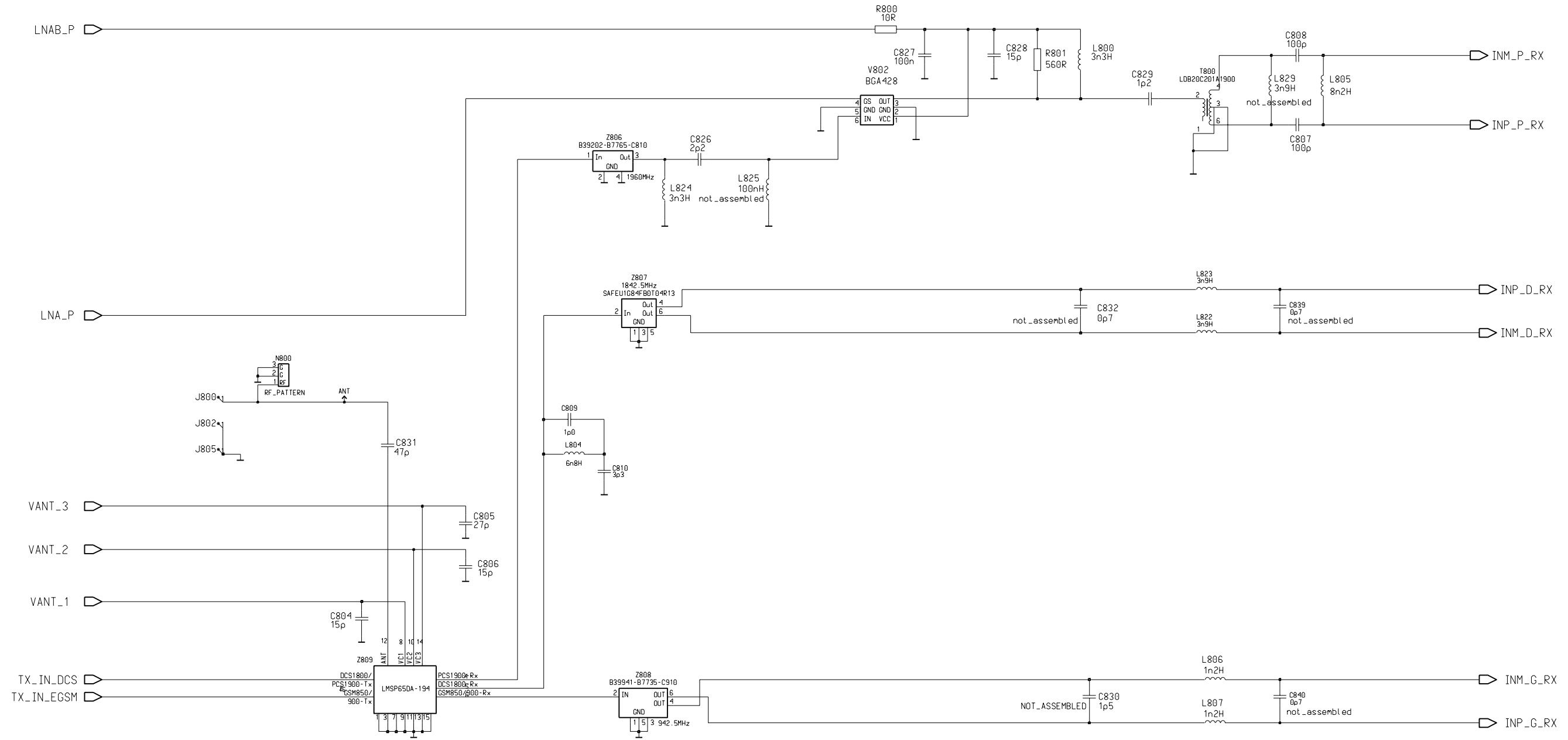

Last references:

- C840
- R807
- L828
- Z809
- V800

HELGA, 1maa\_02, ed. 98

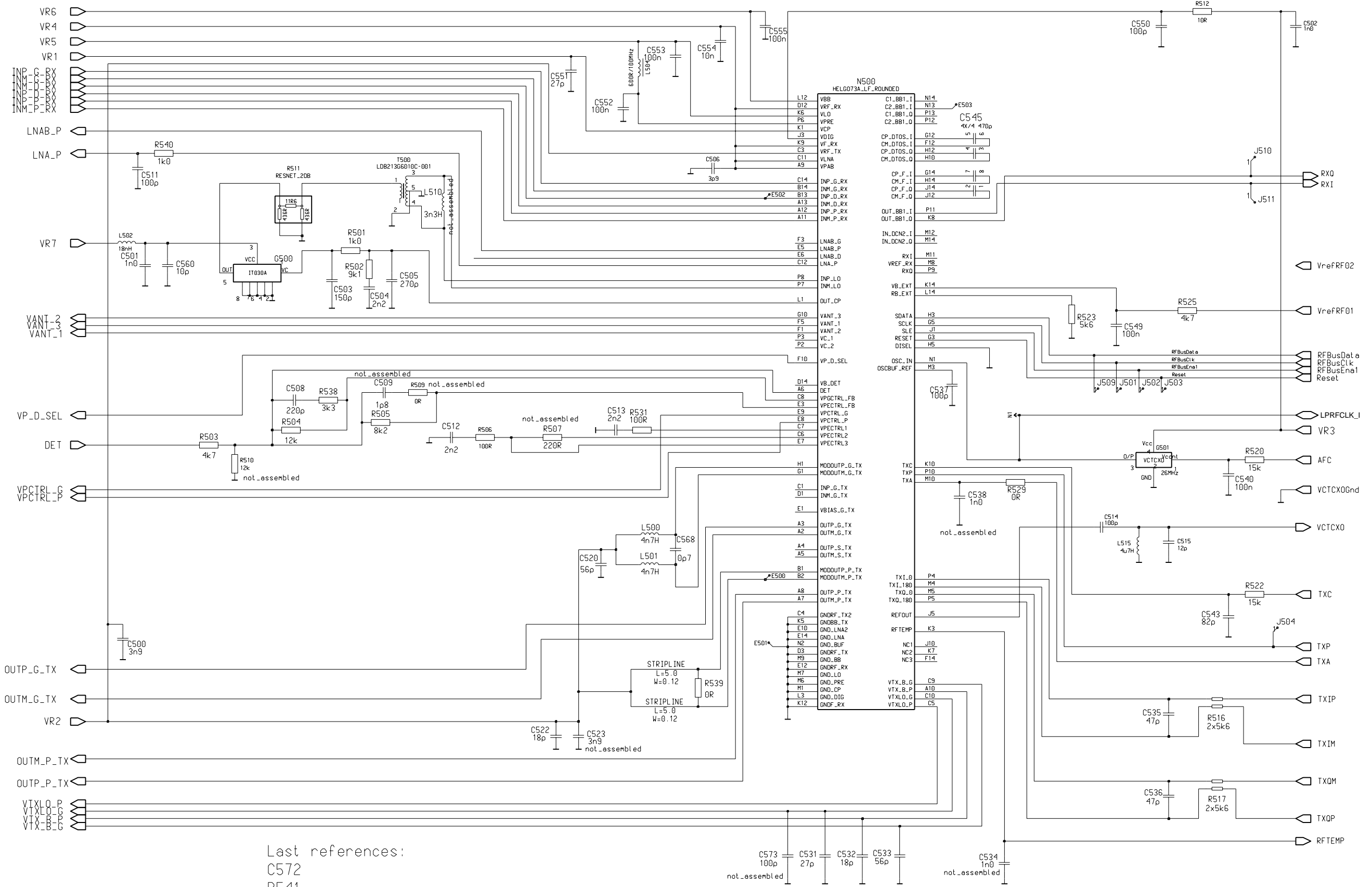

Last references:  
 C572  
 R541  
 L511  
 T501

Copyright (C) Nokia Corporation. All rights reserved.	Name HELGA	Appr dd-mmm-
	Assoc RF module	Des. k1 21-Jan-02

RF9204 Power Amplifier and Power Detection, 1maa\_02, v. 0.2 ed. 65

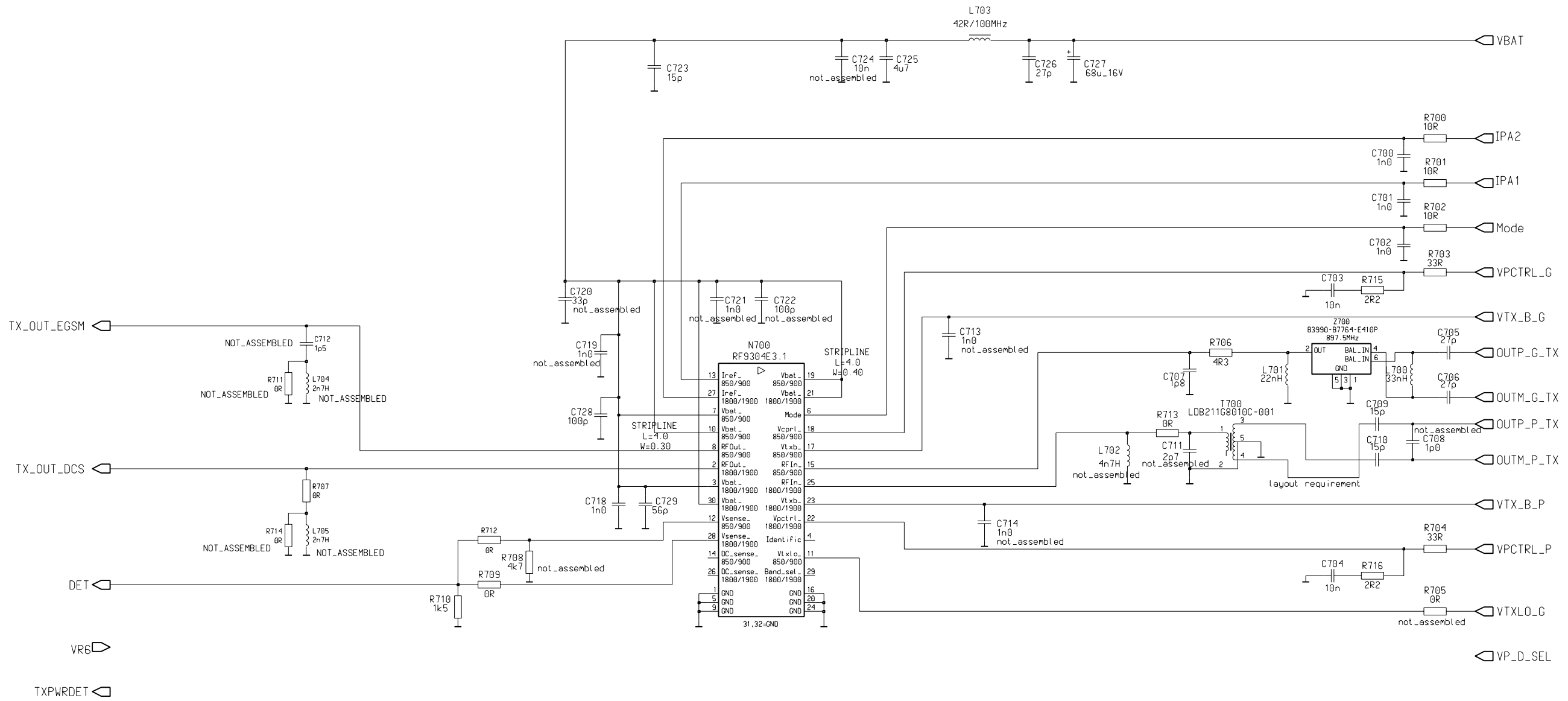

Last references:

- C731
- R714
- L705

BR4.5 Top Level, 1maa\_02, v. 6.1 ed. 43

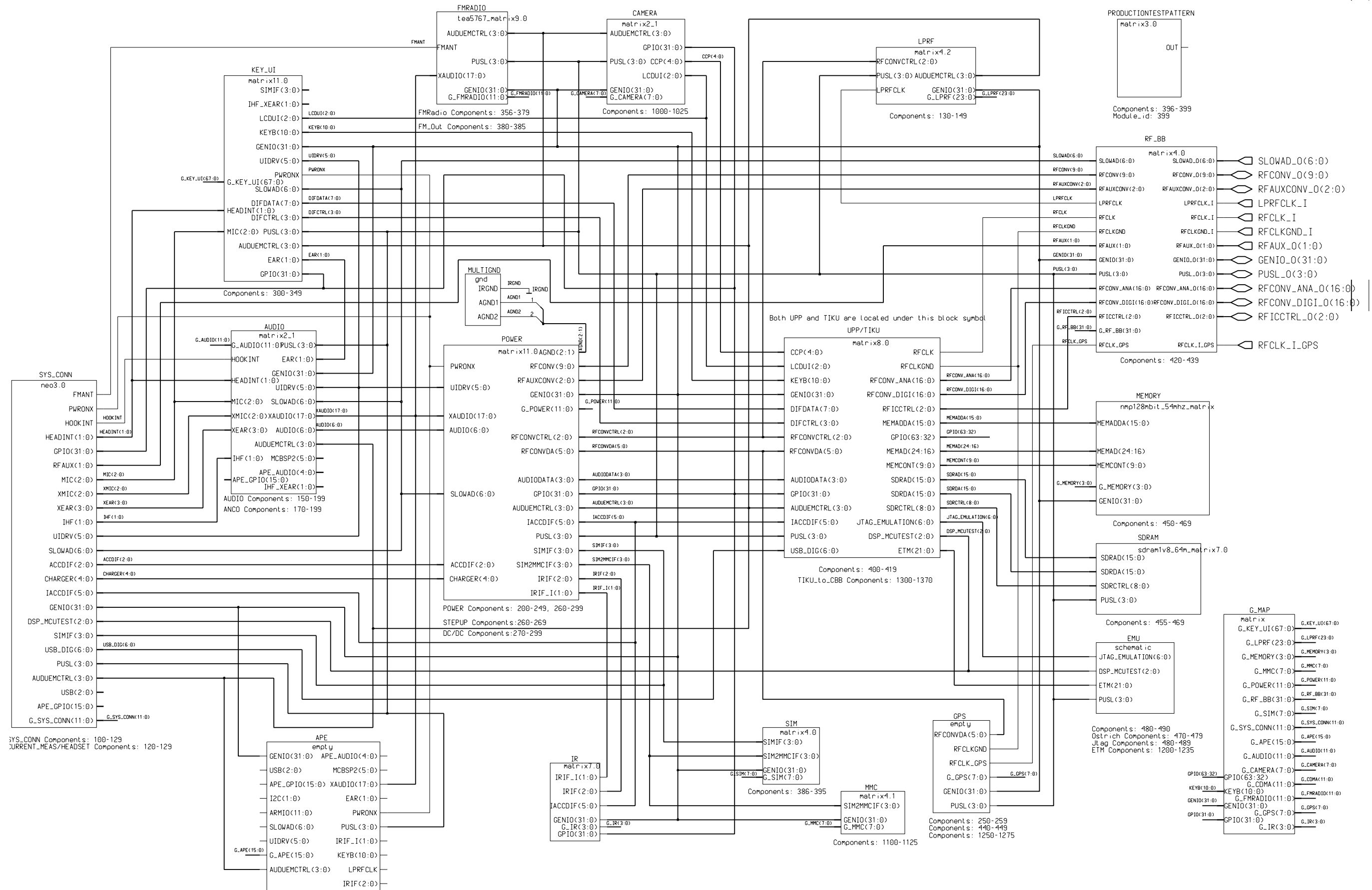

BR45 Audio, 1maa\_02, v. 1.6 ed. 190

- ▷ G\_AUDIO(11:0)
- ▷ EAR(1:0)
- ▷ SLOWAD(6:0)
- ▷ AUDUEMCTRL(3:0)
- ▷ UIDRV(5:0)
- ▷ MIC(2:0)
- ▷ MCBSP2(5:0)
- ▷ APE\_AUDIO(4:0)
- ▷ APE\_GPIO(15:0)
- ▷ IHF\_XEAR(1:0)
- ▷ HOOK INT
- ▷ PUSL(3:0)

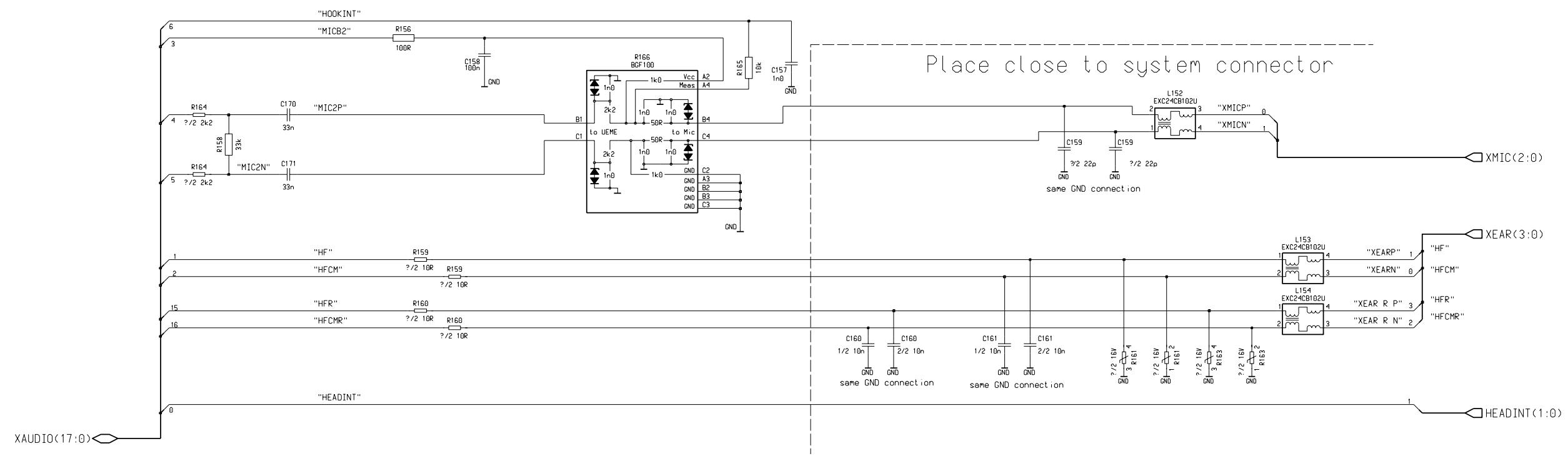
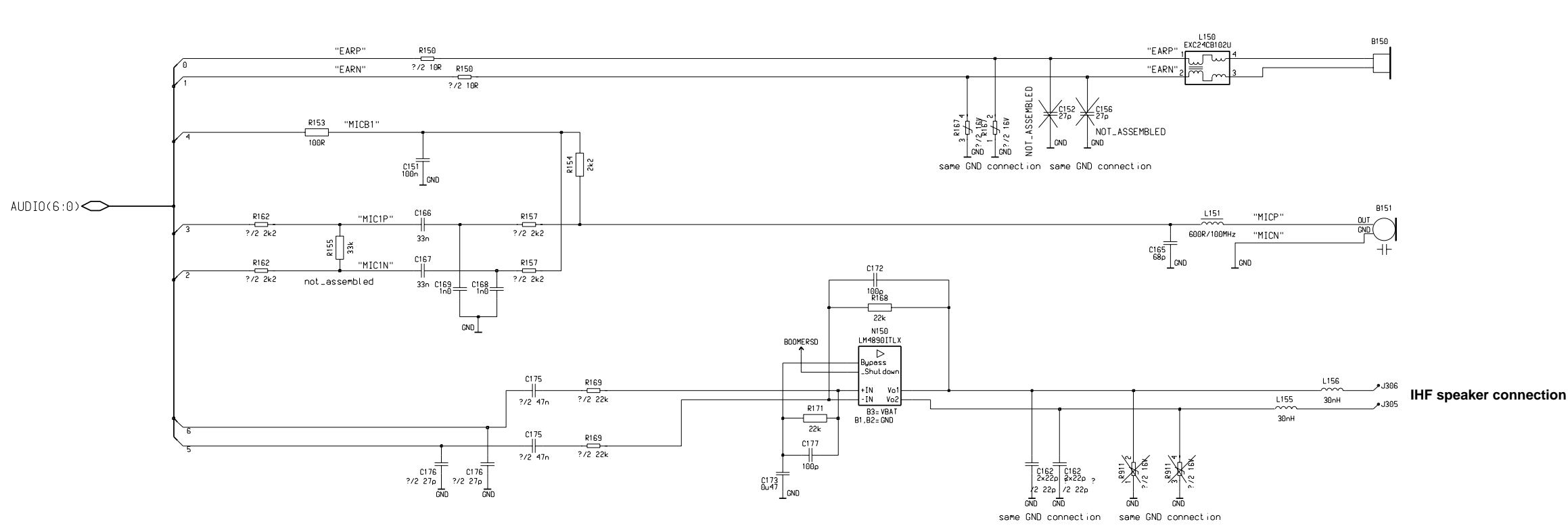

- ▷ IHF(1:0)
- ▷ GENIO(31:0)



Mirage 2 VGA Camera, 1maa\_02, v. 1.1 ed. 206

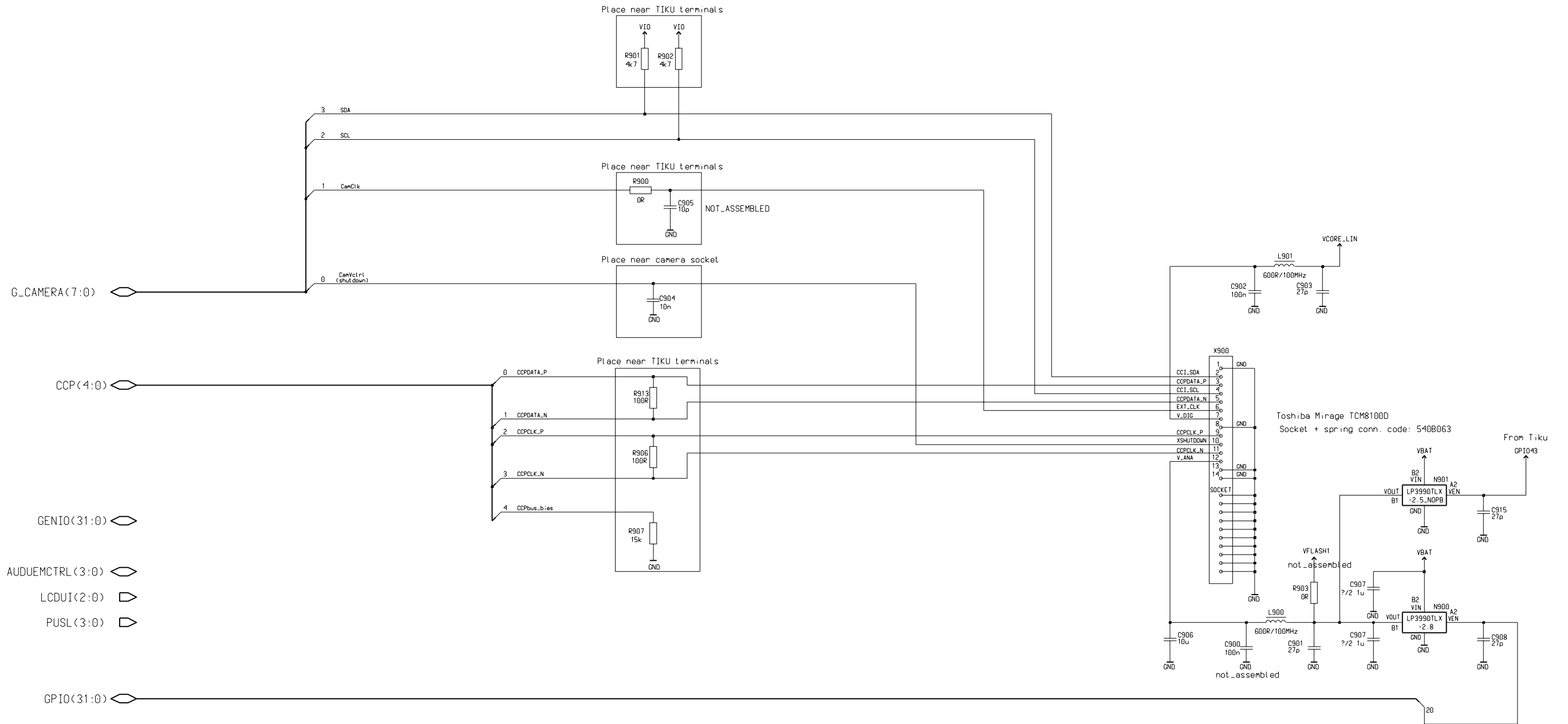

Citizen IR Module 1.8V, 1maa\_02, v. 6.1.8 ed. 56

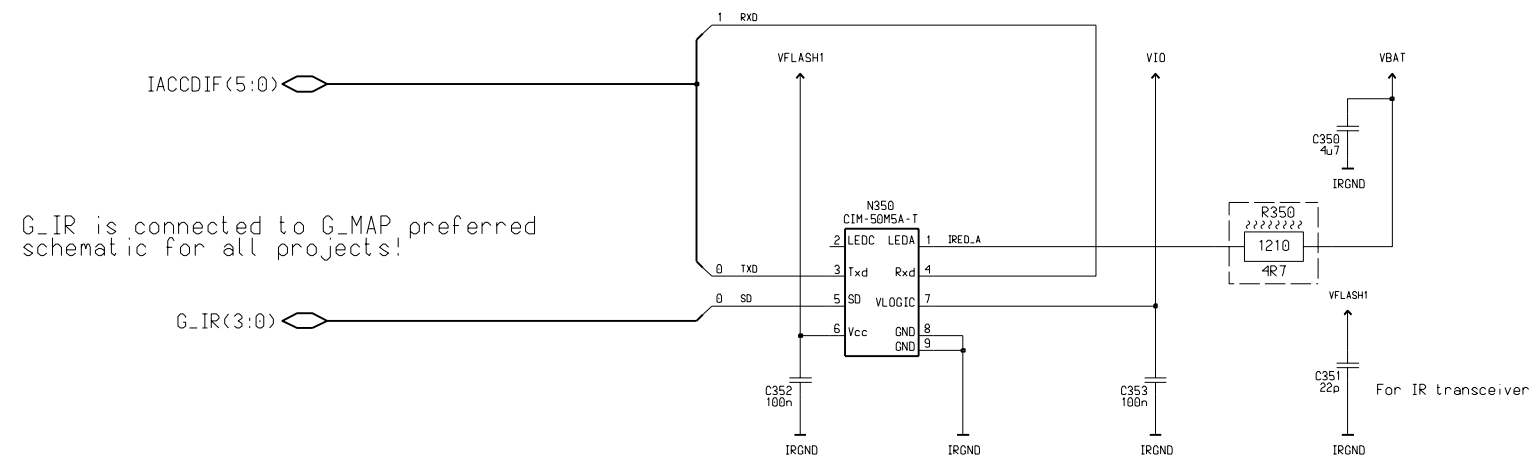

GENIO(31:0)

GPIIO(31:0)

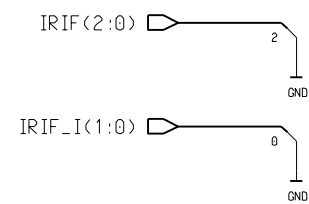

UEM IR level shifters are ground, when 1.8V IR is used!

Used referenses

- C 350 - 353
- N 350
- R 350

IR Resistor 1210, 1maa\_02, v. 0 ed. 6

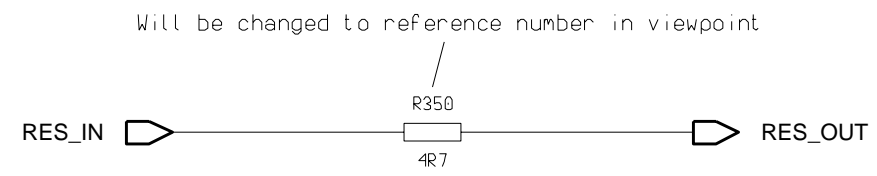

Key UI, 1maa\_02, v. 1 ed. 350

- MIC(2:0) <img alt="connector symbol" data-bbox="135 111 148 124"/>
- PUSL(3:0) <img alt="connector symbol" data-bbox="135 131 148 144"/>
- AUDUEMCTRL(3:0) <img alt="connector symbol" data-bbox="135 151 148 164"/>
- LCDUI(2:0) <img alt="connector symbol" data-bbox="135 171 148 184"/>
- EAR(1:0) <img alt="connector symbol" data-bbox="135 191 148 204"/>
- HEADINT(1:0) <img alt="connector symbol" data-bbox="135 211 148 224"/>
- SIMIF(3:0) <img alt="connector symbol" data-bbox="135 231 148 244"/>
- IHF\_XEAR(1:0) <img alt="connector symbol" data-bbox="135 251 148 264"/>
- SLOWAD(6:0) <img alt="connector symbol" data-bbox="135 271 148 284"/>
- GENIO(31:0) <img alt="connector symbol" data-bbox="135 291 148 304"/>
- KEYB(10:0) <img alt="connector symbol" data-bbox="135 311 148 324"/>
- GPI0(31:0) <img alt="connector symbol" data-bbox="135 331 148 344"/>

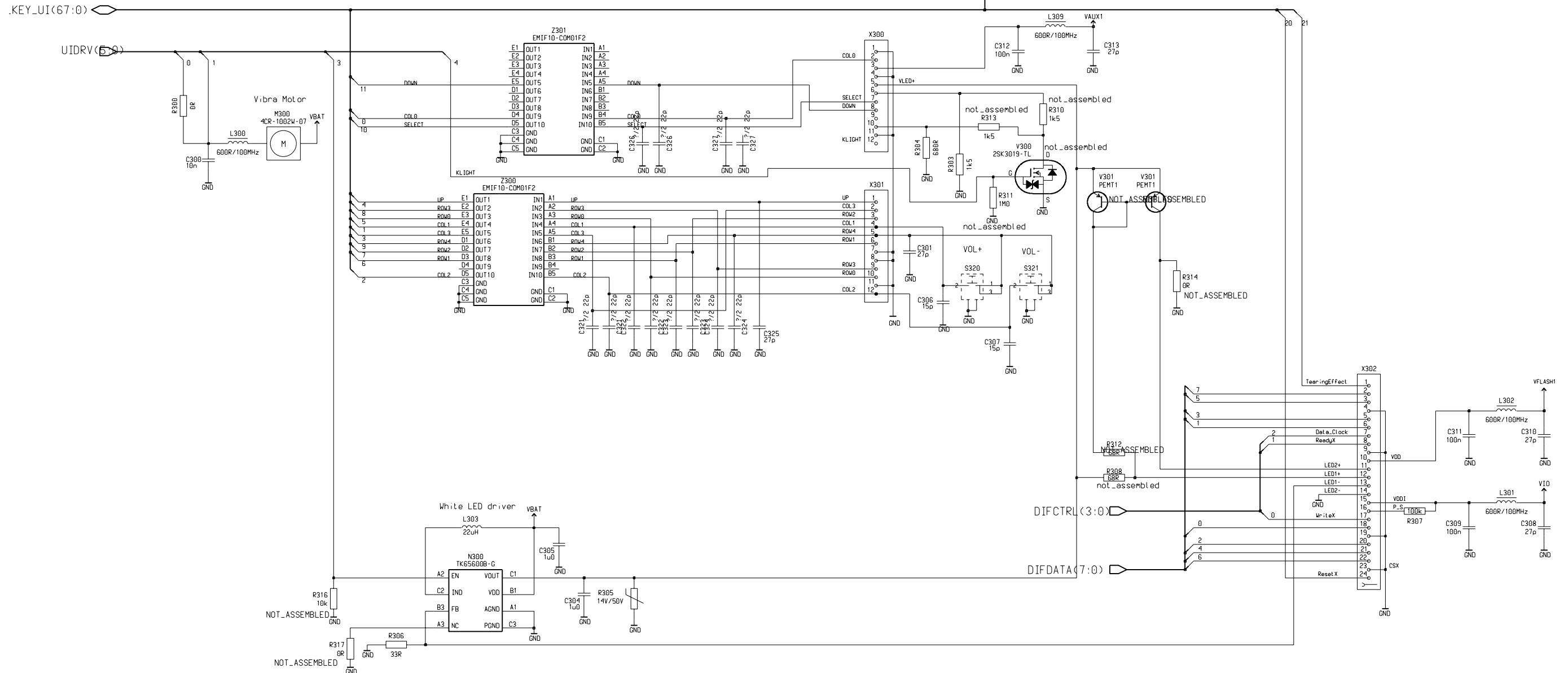
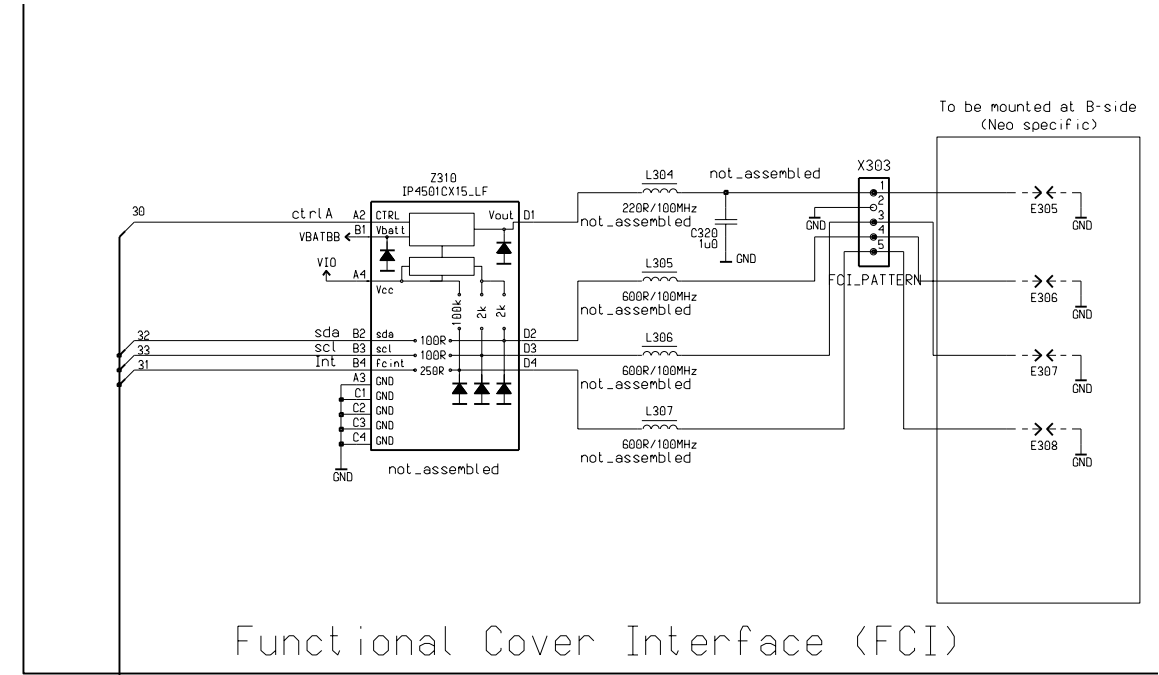
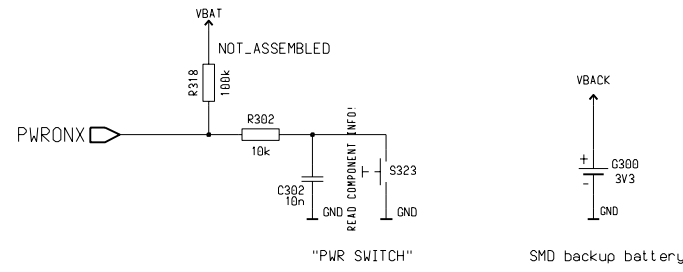

Flash Memory 128 Mbit, 1maa\_02, v. 2.0 ed. 81

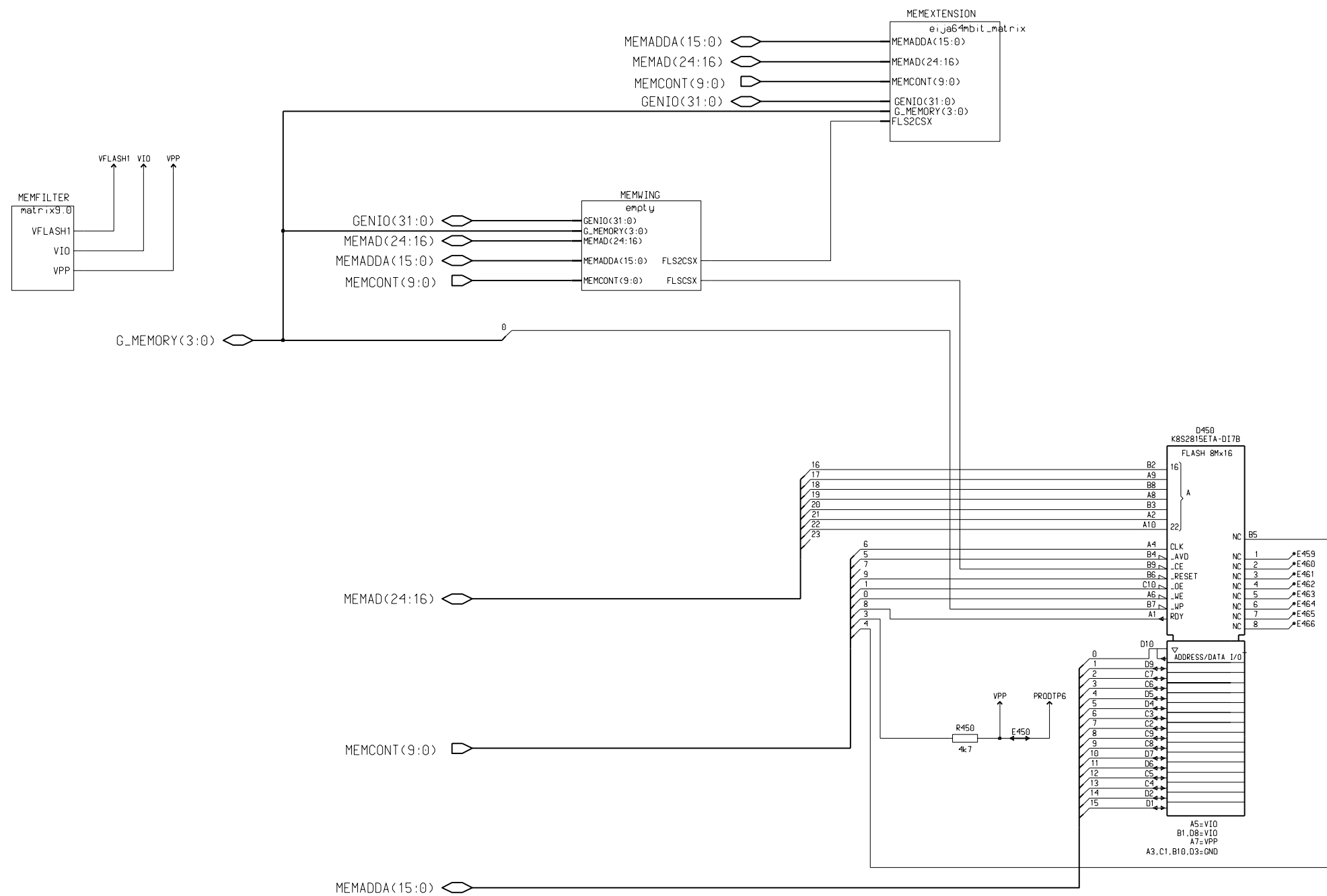

Discrete Capacitors for two Memories without VFlash1, 1maa\_02, v. 1.3 ed. 14

Decoupling capacitors for 1st flash



Decoupling capacitors for 2nd flash

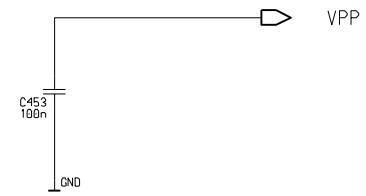
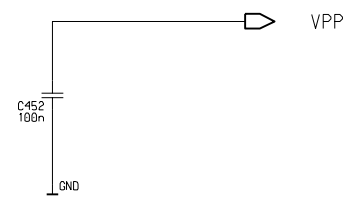
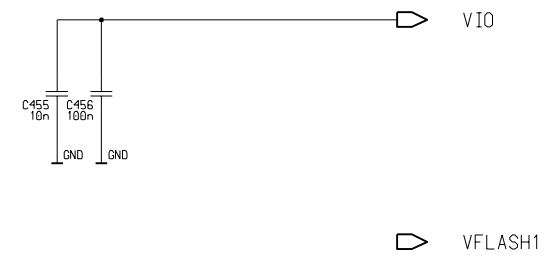

Flash Memory 64 Mbit NAND, 1maa\_02, v. 2.0 ed. 68

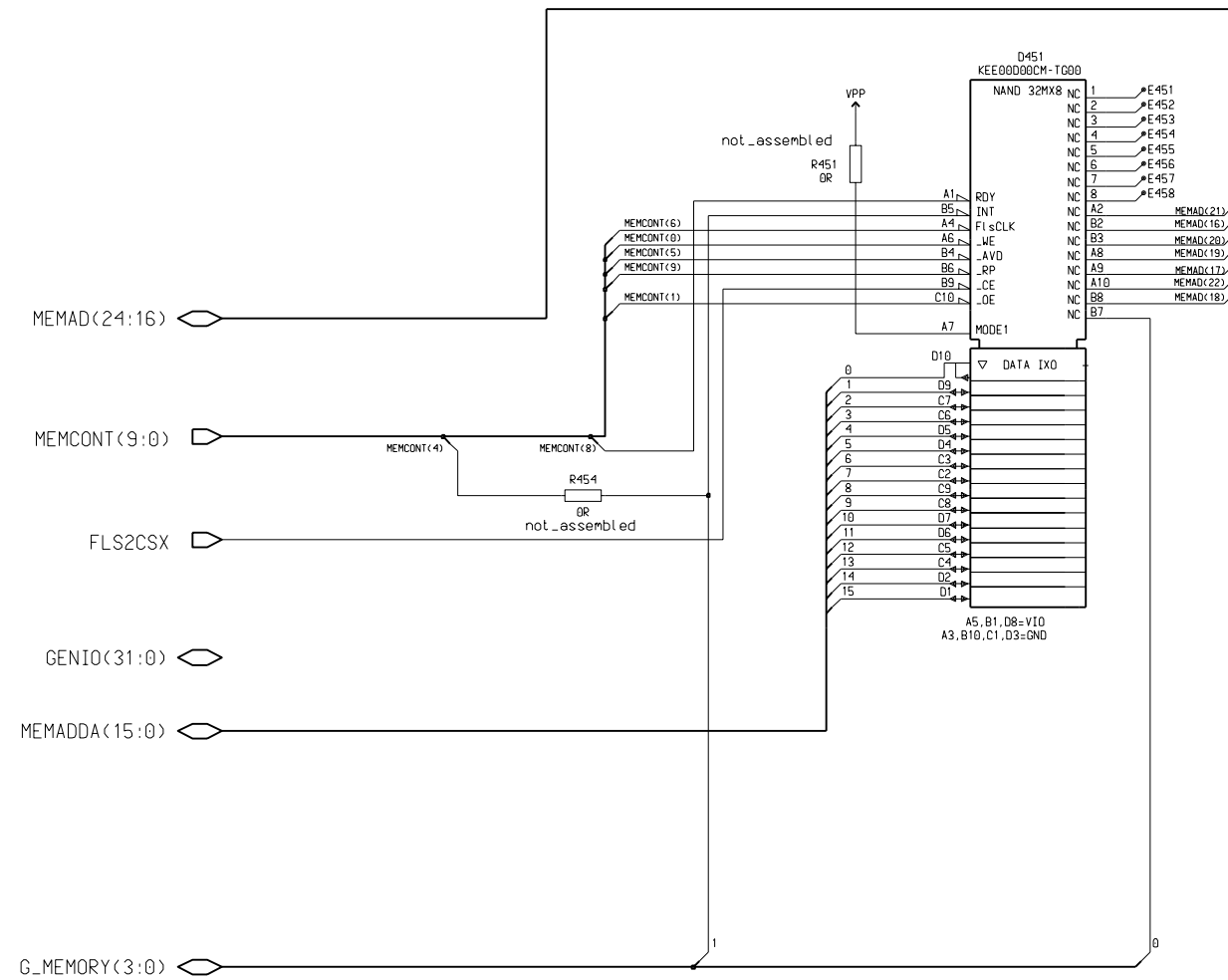

Resistors R451 and R454 are added into schematics to make it possible to replace NAND FLASH by NOR FLASH if necessary. Later when NAND FLASH will achieve more mature state, these resistors will be removed.

In case of NAND FLASH, memory pin A7 and B7 need to be n.c. on PWB. B5 need to be connected to GENIO(13) only.

MMC Interface, 1maa\_02, v. 2.1 ed. 80

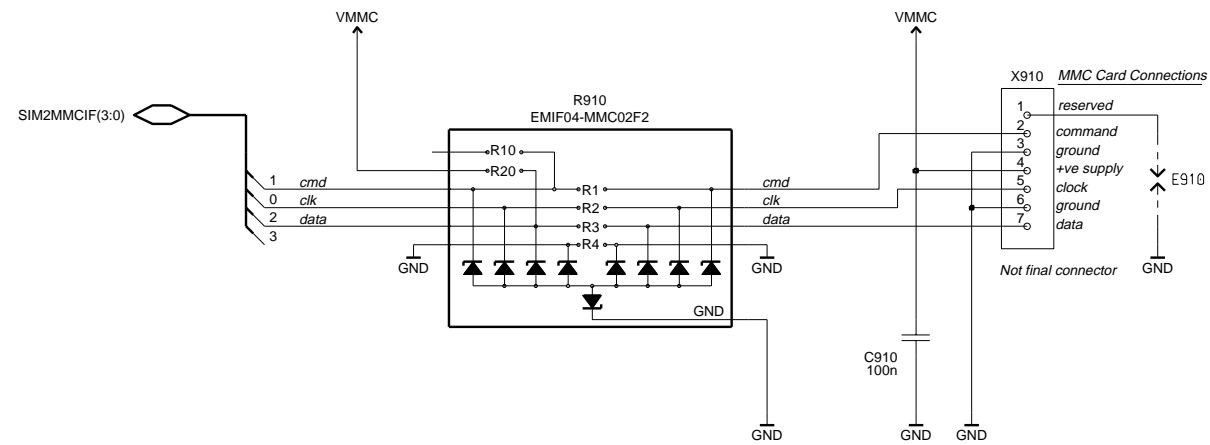

NOTE: The MMC specification imposes the following impedance limits  
 Command pullup resistance 4.7k to 100k  
 Data pullup resistance 50k to 100k  
 EMIF02-MMC R10=13k (therefore only suitable for command line)  
 EMIF02-MMC R20=56k (therefore only suitable for data line)  
 EMIF02-MMC R1/R2/R3/R4=47R  
 UEME includes a 13k pullup between GEN28IO2 (command) and VAUX1  
 so EMIF02-MMC R10 is left unconnected. UEME has no pullup on GEN28IO3 (MMC data)

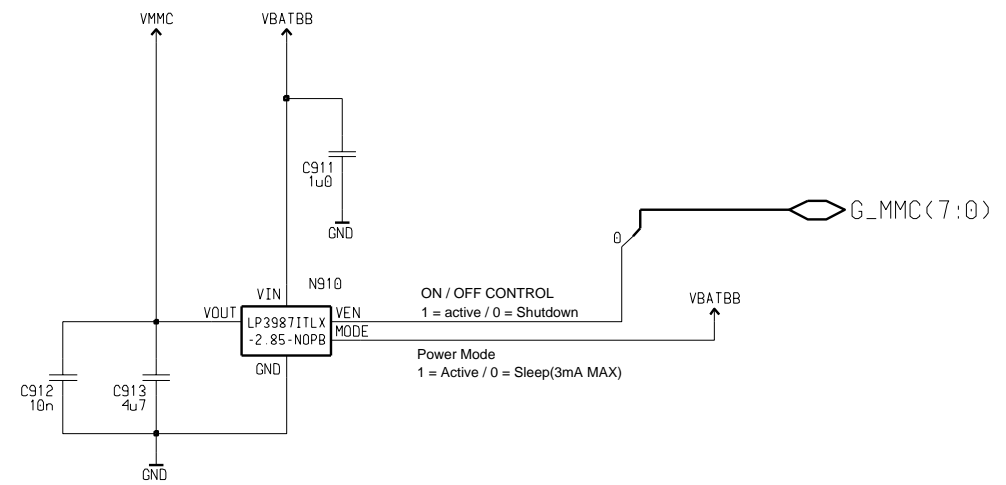



UEME Power Management - Dual 1 uF 6V3 Capacitors, 1maa\_02, v. 1.0 ed. 321

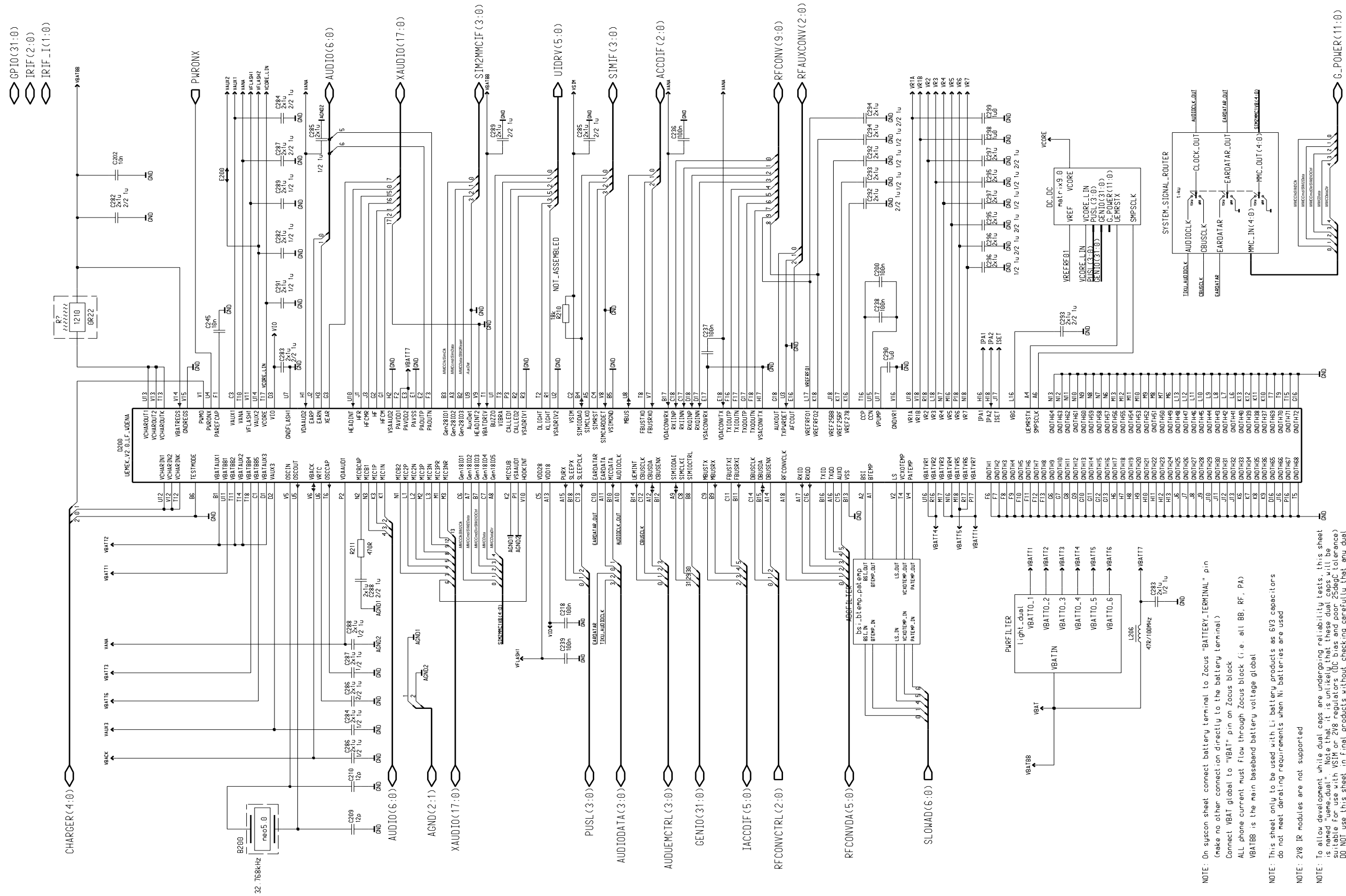

NOTE: On syscon sheet connect battery terminal to Zocus "BATTERY\_TERMINAL" pin (make no other connection directly to the battery terminal)  
 Connect VBAT global to "VBAT" pin on Zocus block  
 ALL phone current must flow through Zocus block (i.e. all BB, RF, PA)  
 VBATBB is the main baseband battery voltage global

NOTE: This sheet only to be used with Li battery products as 6V3 capacitors do not meet derating requirements when Ni batteries are used

NOTE: 2V8 IR modules are not supported

NOTE: To allow development while dual caps are undergoing reliability tests, this sheet is named "ueme\_dual". Note that it is unlikely that these dual caps will be suitable for use with V5IM or V28 regulators (DC bias and poor 25degC tolerance) DO NOT use this sheet in final products without checking carefully that any dual capacitors used are OK for bias, tolerance and temperature vs. UEME requirements

UEME ADC Filter Block - BSI, BTEMP and Active PATEMP, 1maa\_02, v. 1.0

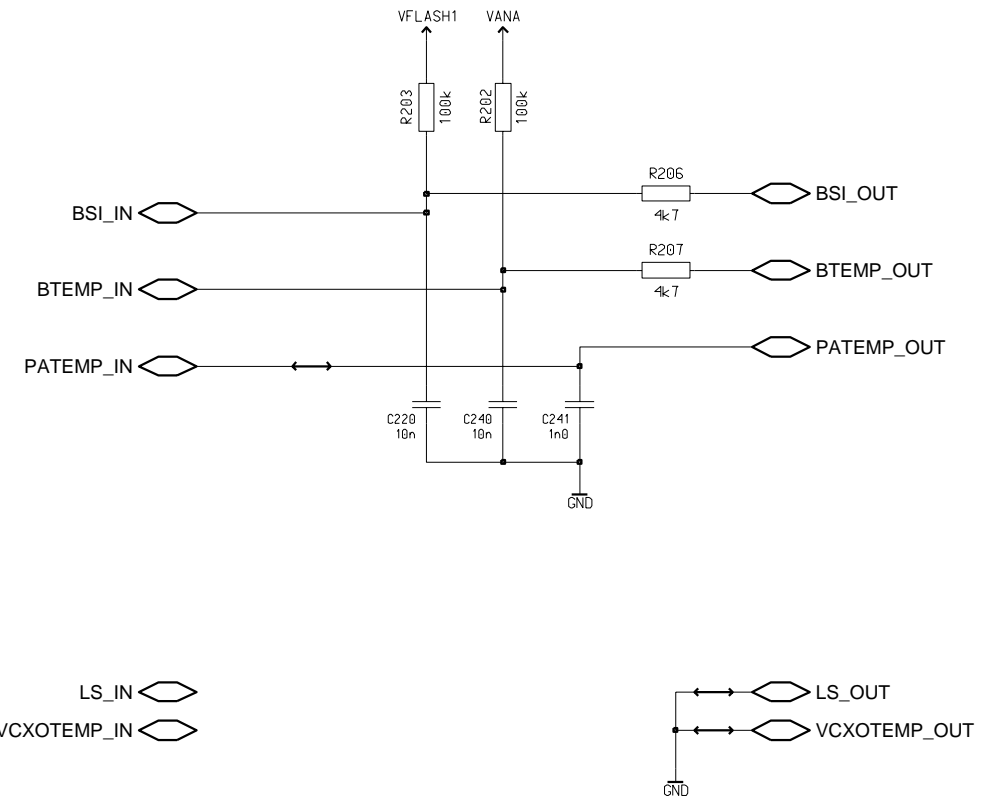

NOTE: Helga RF drives PATEMP directly  
so PATEMP does not need a pullup

DC\_DC for TIKU and VIO, 1maa\_02, v. 1.7 ed. 79

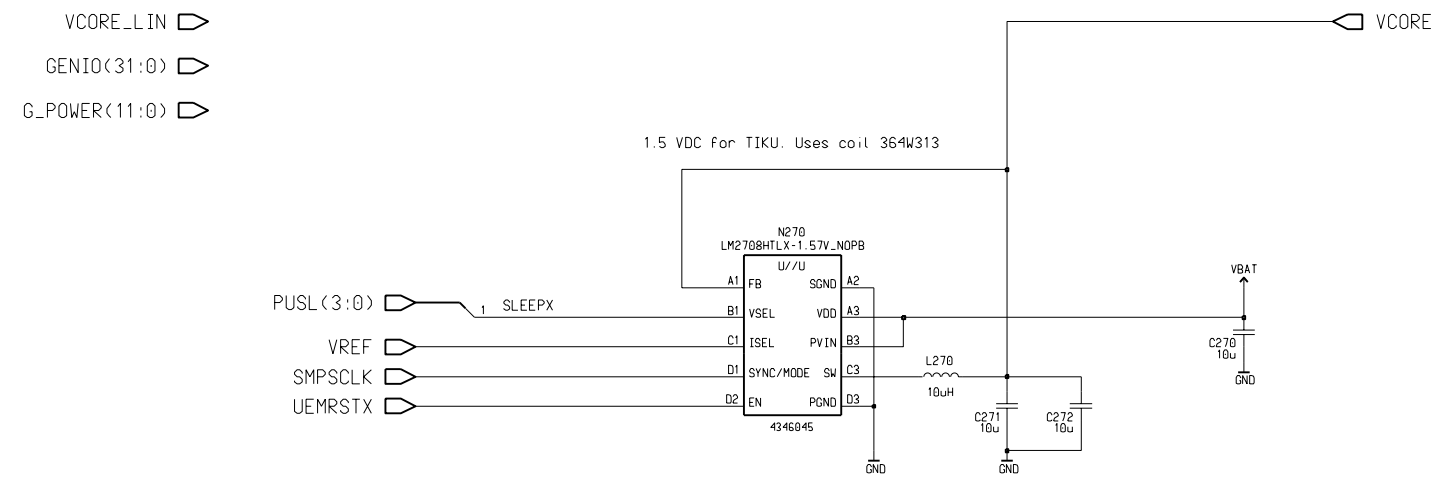

Light Filtering for Projects using 1uF Caps, 1maa\_02, v. 1.0

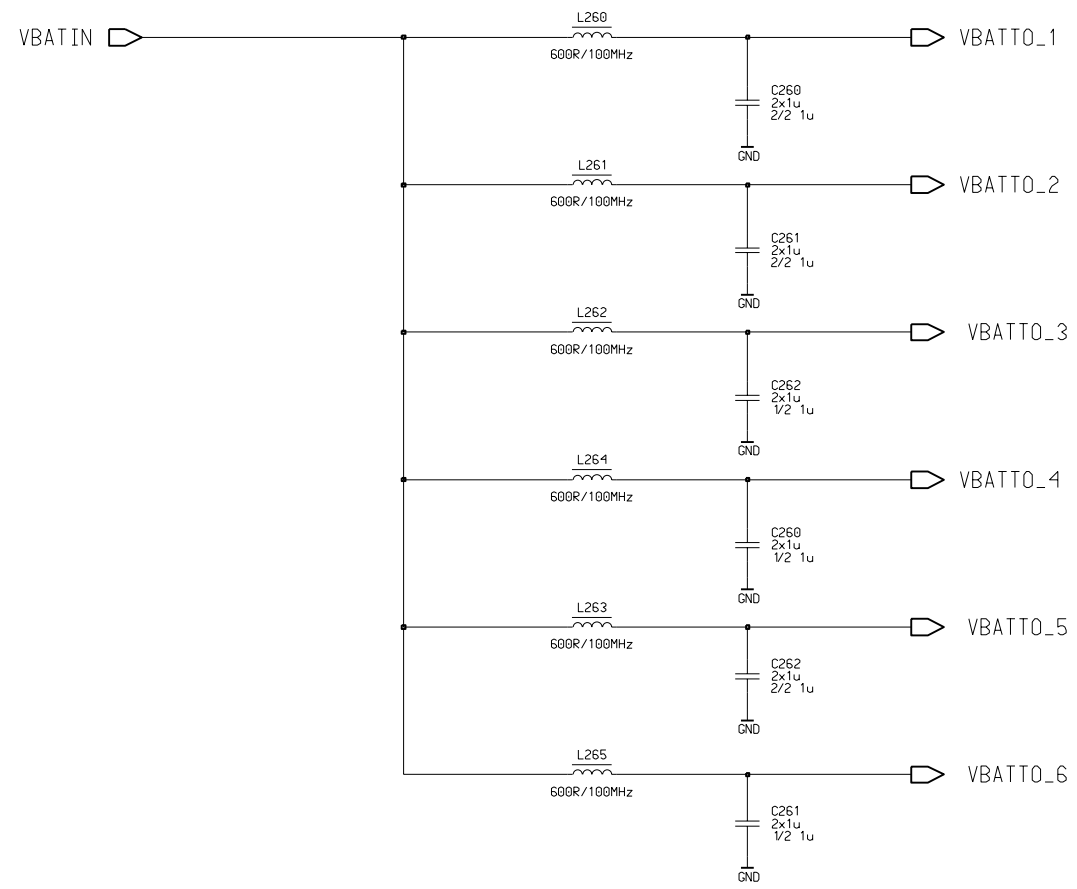

NOTE: This sheet uses dual 1uF capacitors. Check that full approval has been granted for these parts before use, or use this sheet at risk

Tiku Systems, 1maa\_02, v. 1.0

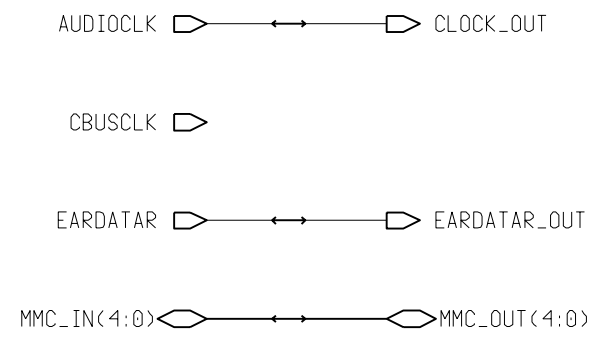

E916

32KHz Crystal- Micro Crystal CC4VT2, 1maa\_02, v. 0 ed. 8

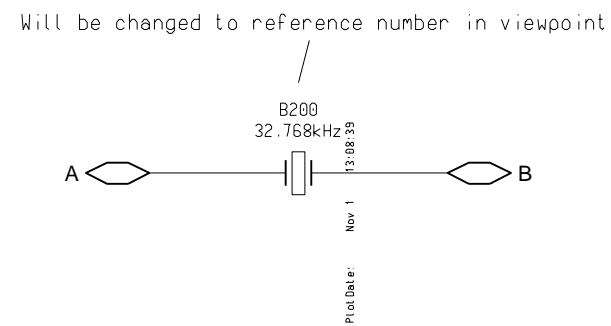

GSM RF - Baseband Interface, 1maa\_02, v. 1.3 ed. 65

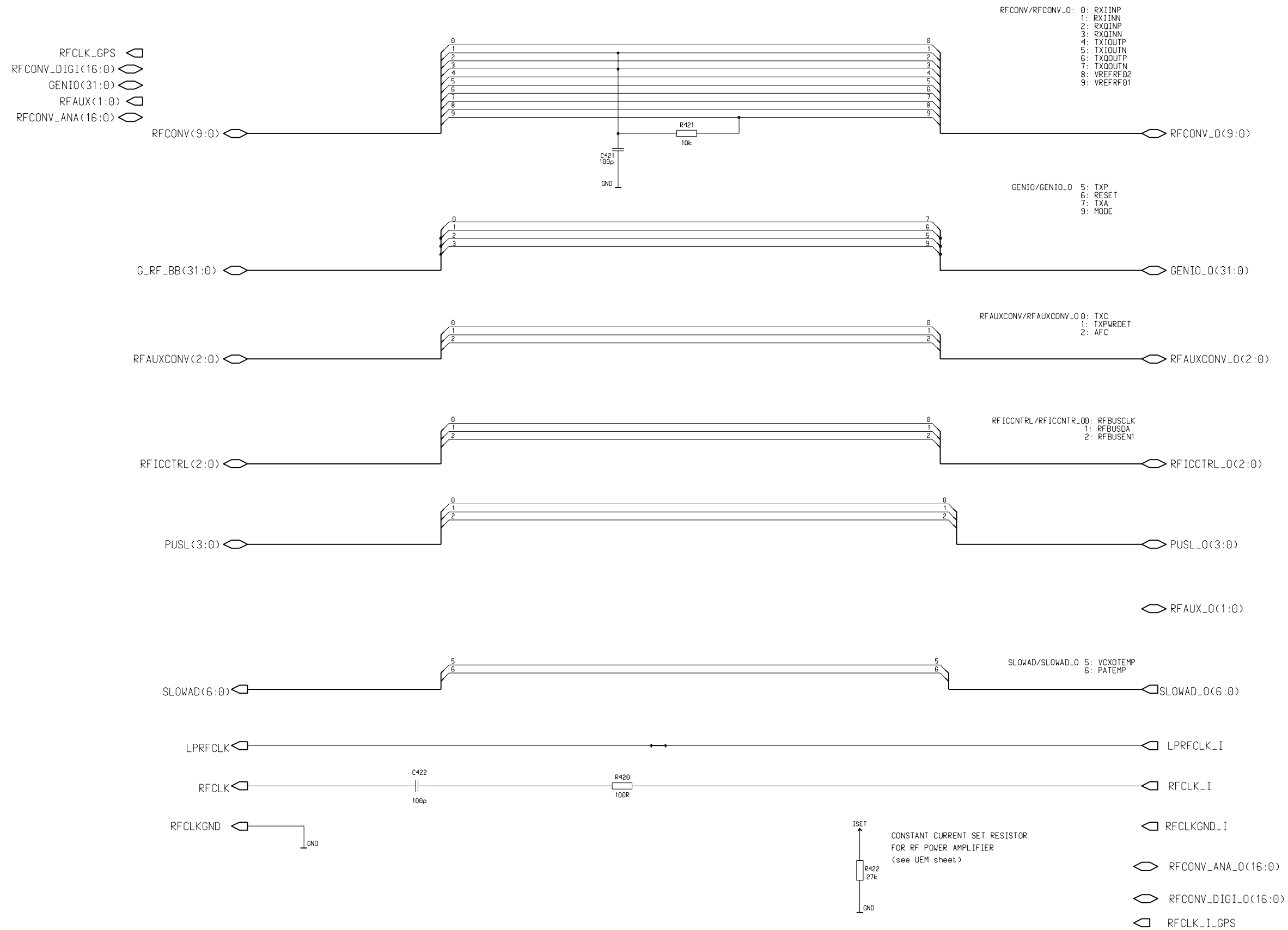

IPA1 AND IPA2 ARE USED IN RF, THE TOLERANCE OF R422 IS 1% (0402, 1430873)

64Mbit 2V8 SDRAM Memory, 1maa\_02, v. 1.0 ed. 68

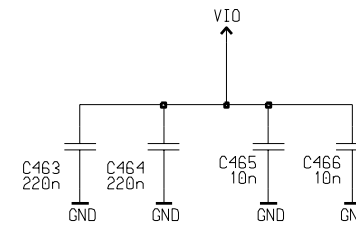
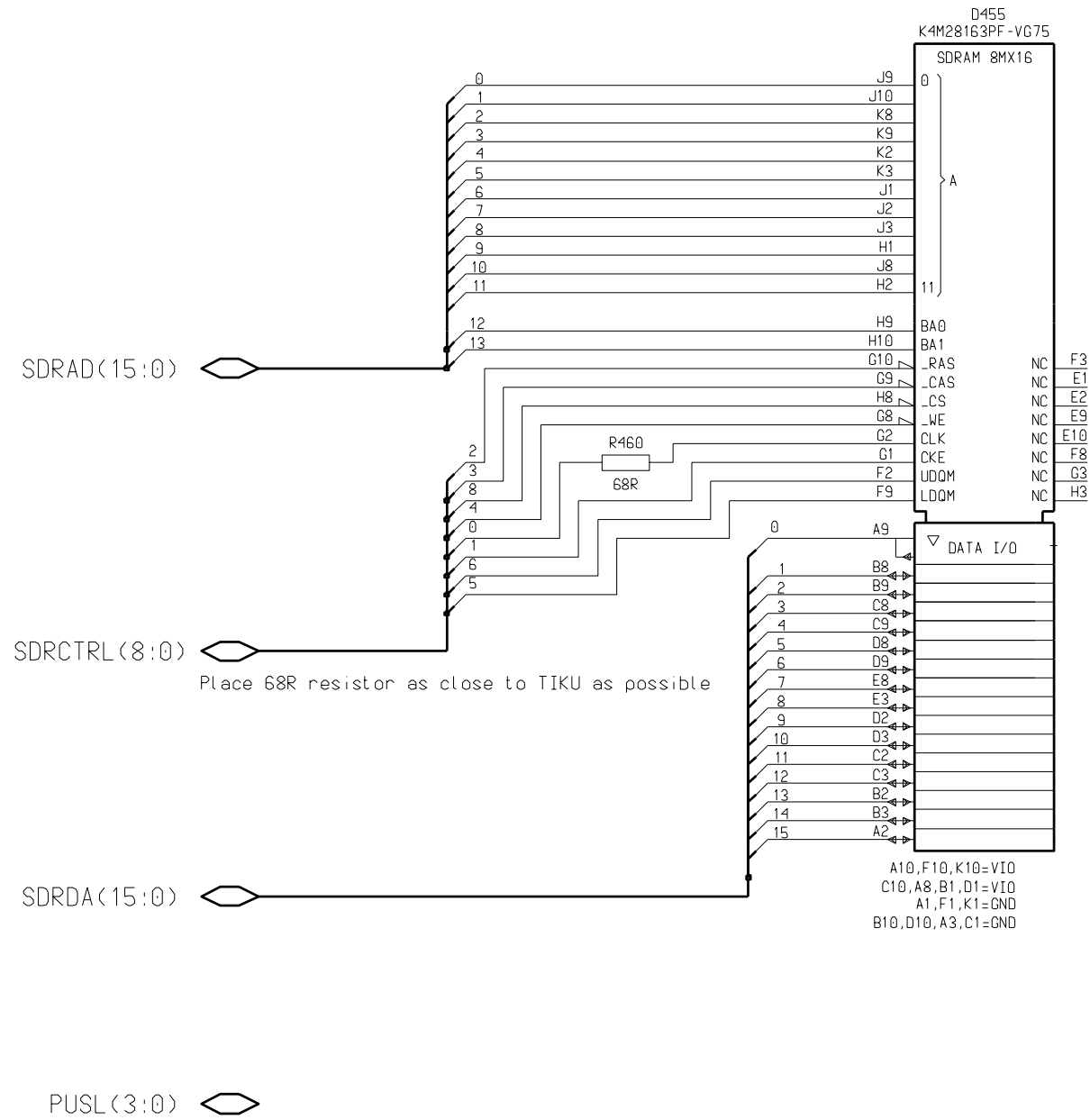

SIM Reader, 1maa\_02, v. 1.3 ed. 67

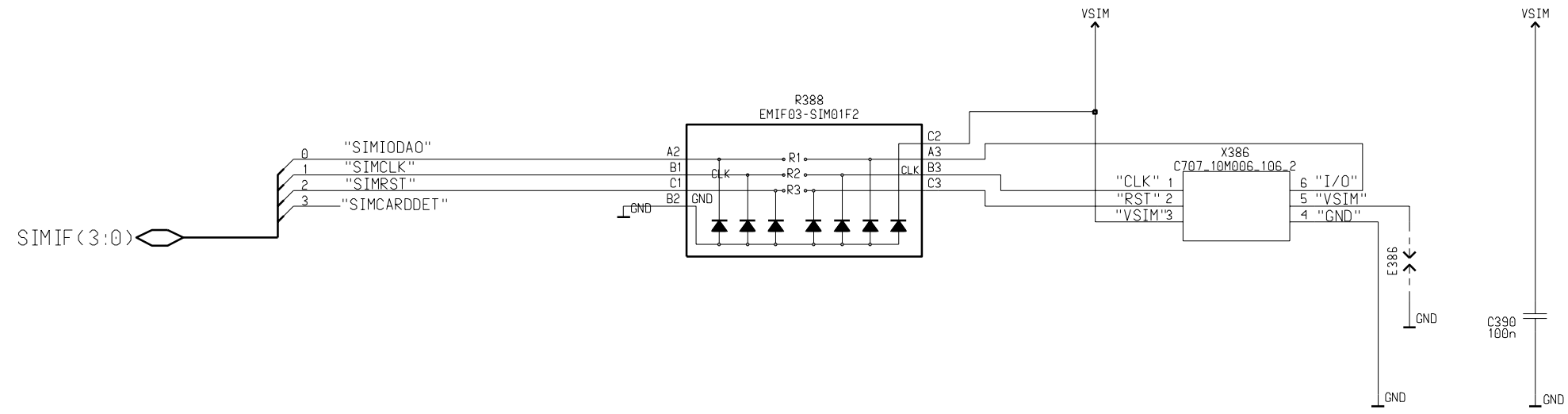

GENIO(31:0)

SIM2MMCIF(3:0)

G\_SIM(7:0)



System Connector, 1maa\_02, v. 0.0 ed. 204

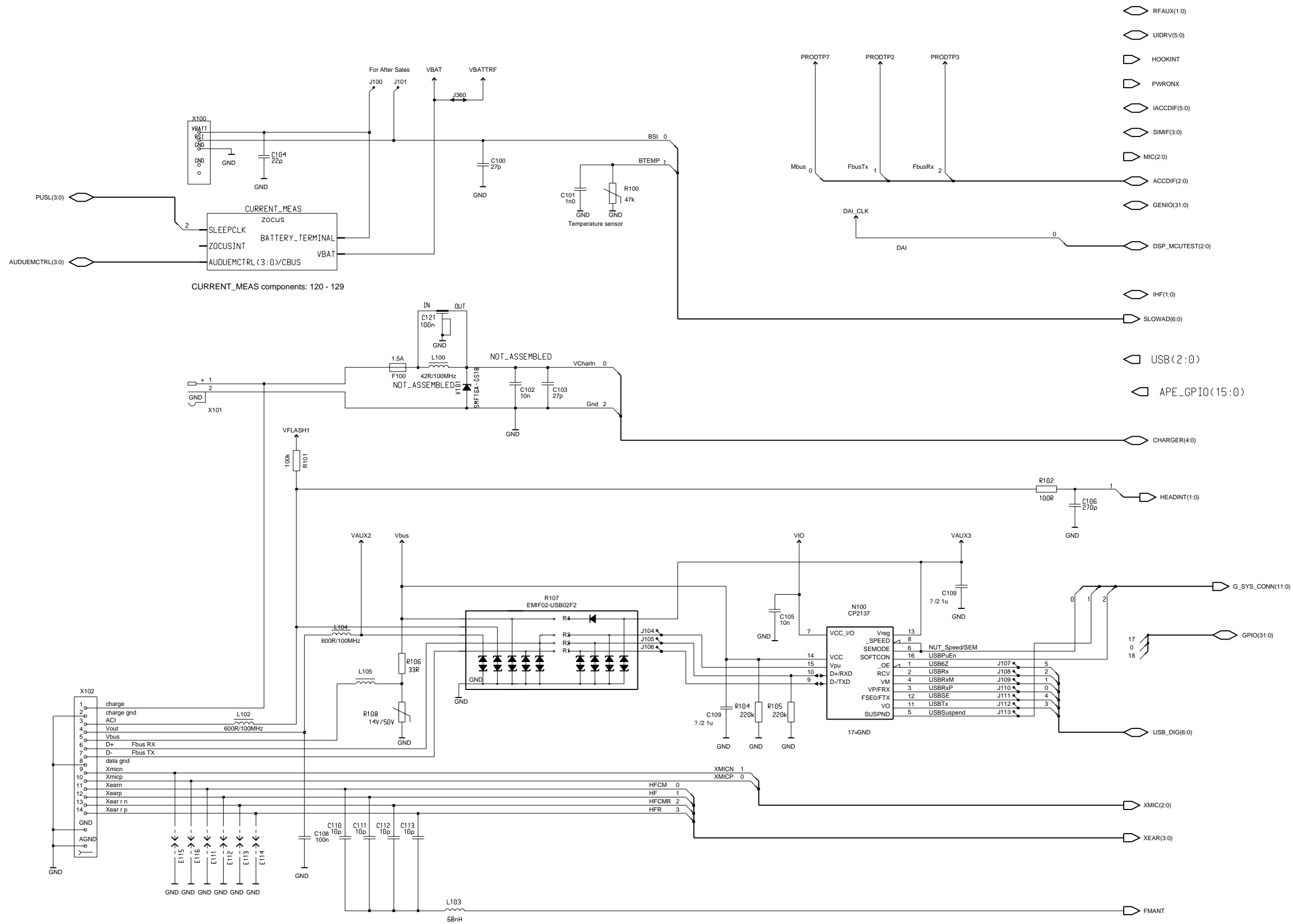

Current Measure, 1maa\_02, v. 0 ed. 19

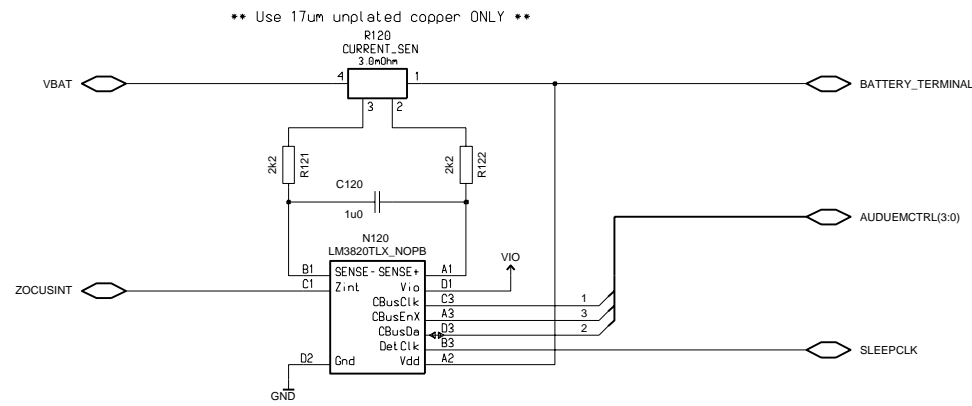

5 pin Test Pattern, 1maa\_02, v. 2.0 ed. 53

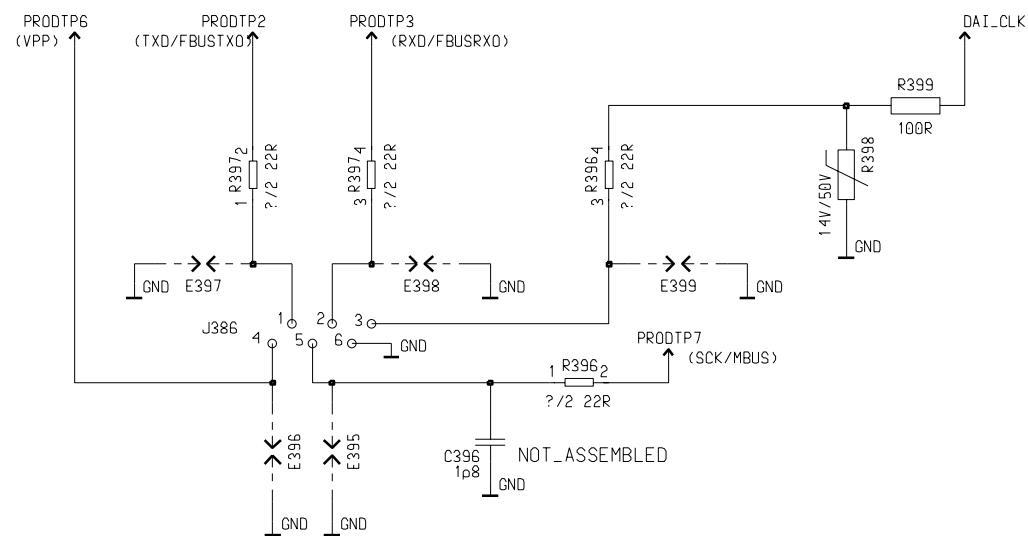



Discrete Decoupling Capacitors for Tiku, 1maa\_02, v. 0 ed. 12

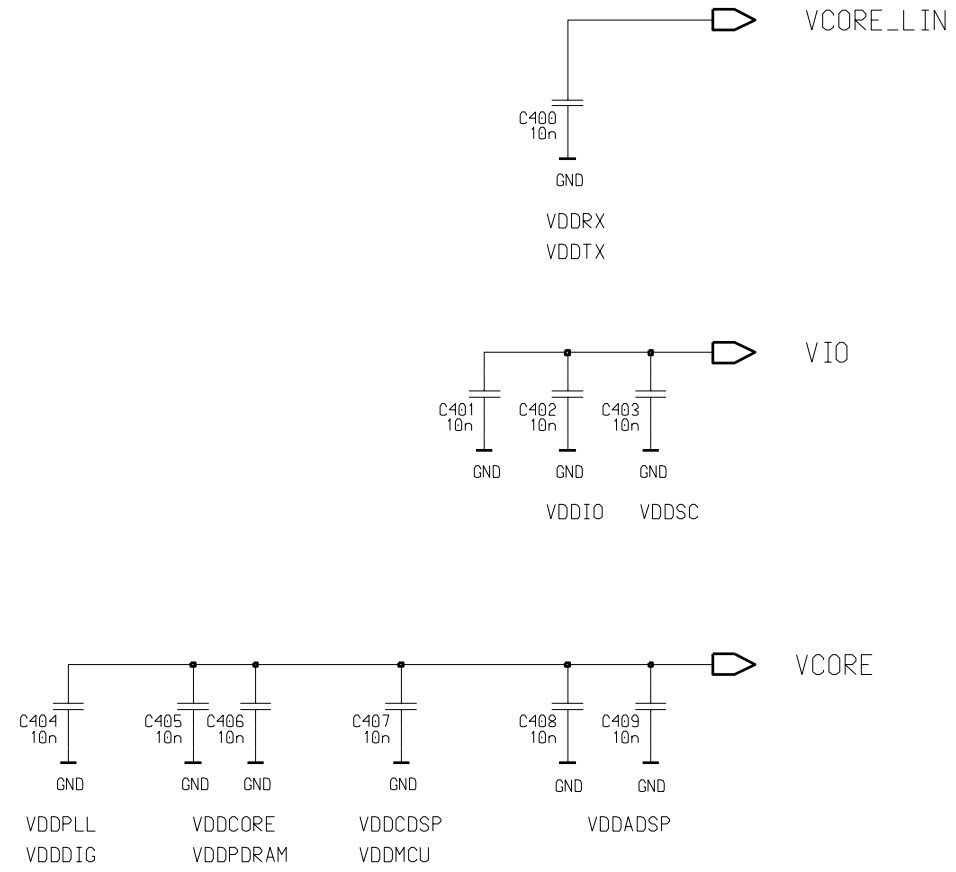

TikuEDGE Bus Conversion Sheet, 1maa\_02, v. 1.2 ed. 104

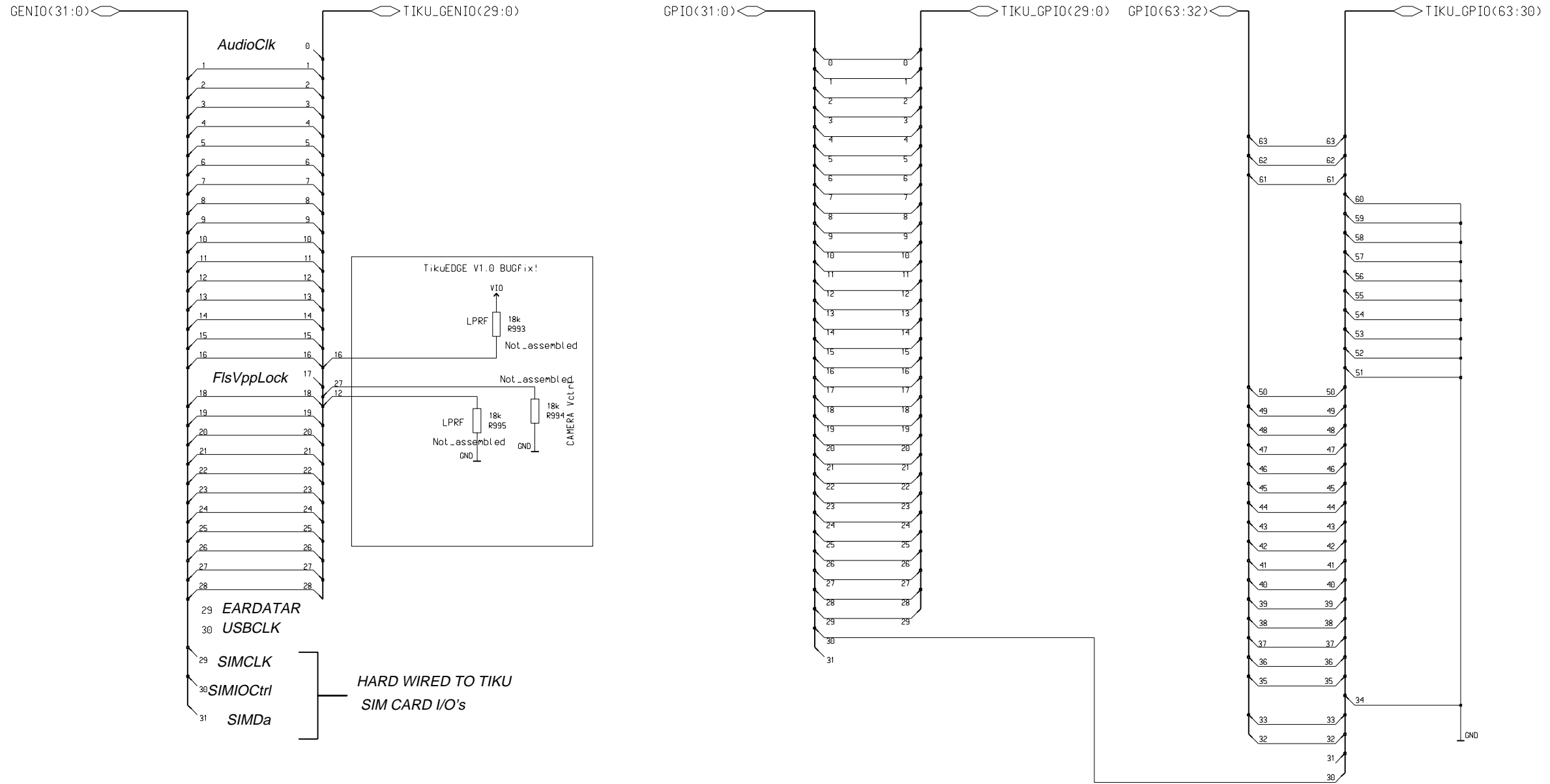

FM Radio Unit, 1maa\_02, v. 1.3 ed. 199

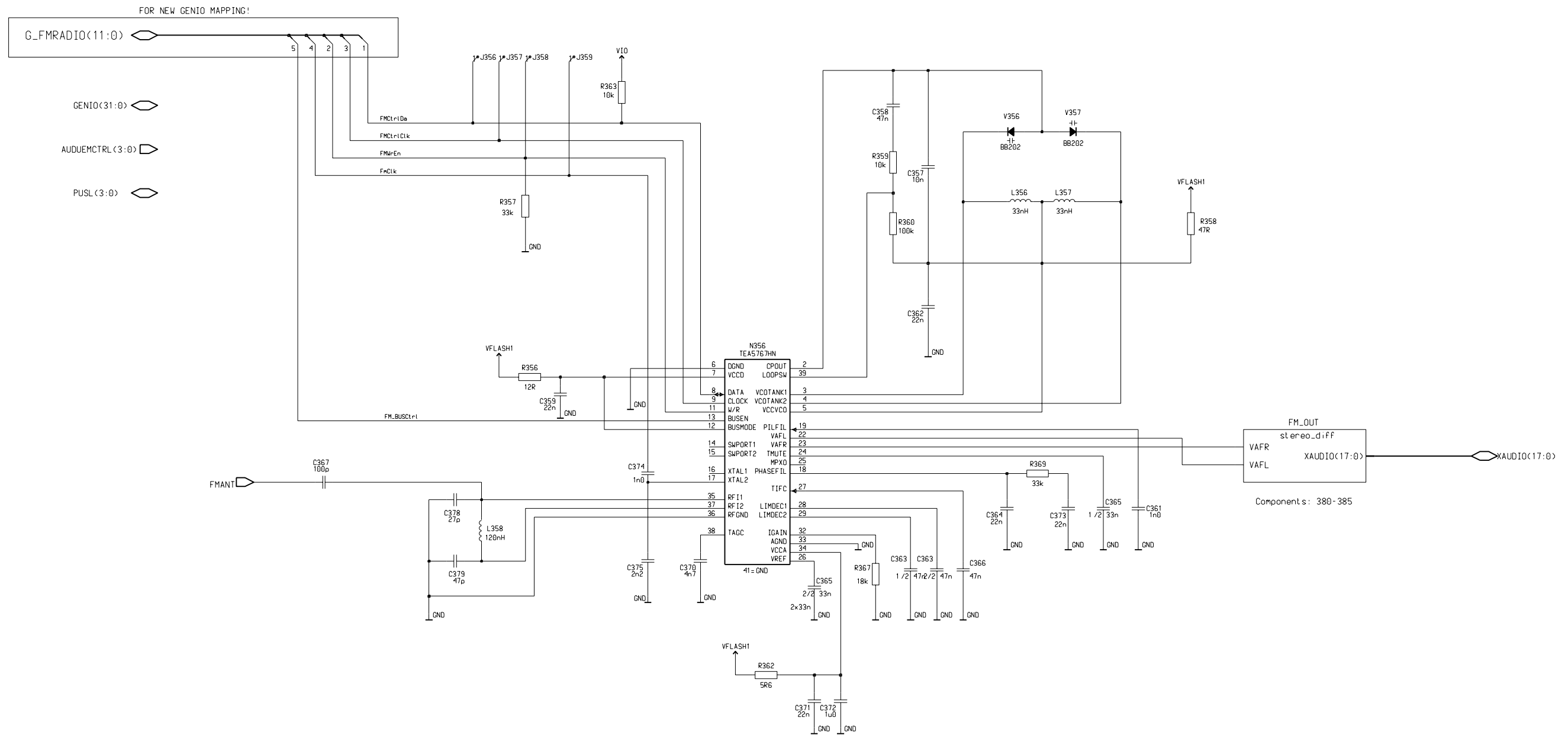

UPDATE symbol to support RDS

Notice:

C374 (1n0) and C375 (2n2) are configured for 32kHz reference clock  
 If reference clock is 6.5MHz, use C374 (3p9) and C375 (10p)

Differential Stereo, 1maa\_02, v. 0.0 ed. 7

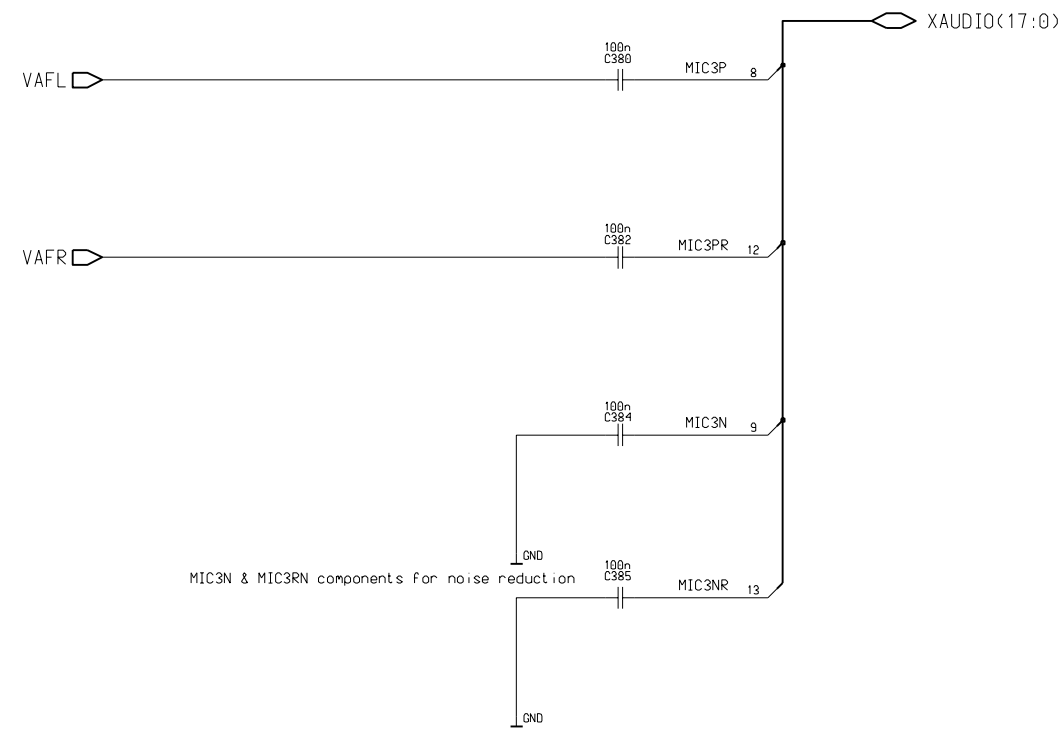

Low Power RF Module, 1maa\_02, ed. 148

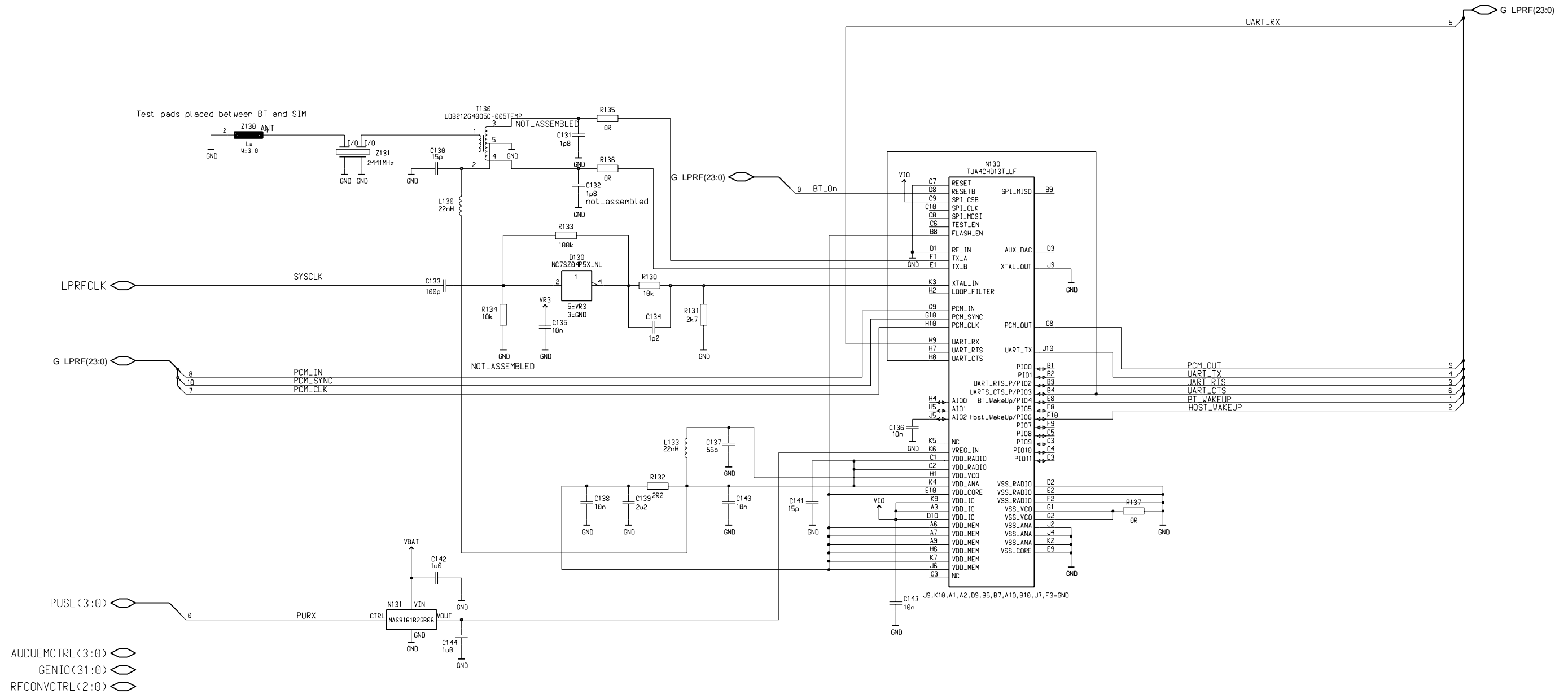

- AUDUEMCTRL(3:0)
- GENIO(31:0)
- RFCONVCTRL(2:0)



GENIO and GPIO Connection Block, 1maa\_02, v. 0.0 ed. 42

TIKU GPIO & GENIO BUSES

- G\_AUDIO(11:0)
- G\_APE(15:0)
- G\_CDMA(11:0)
- G\_GPS(7:0)
- G\_SIM(7:0)

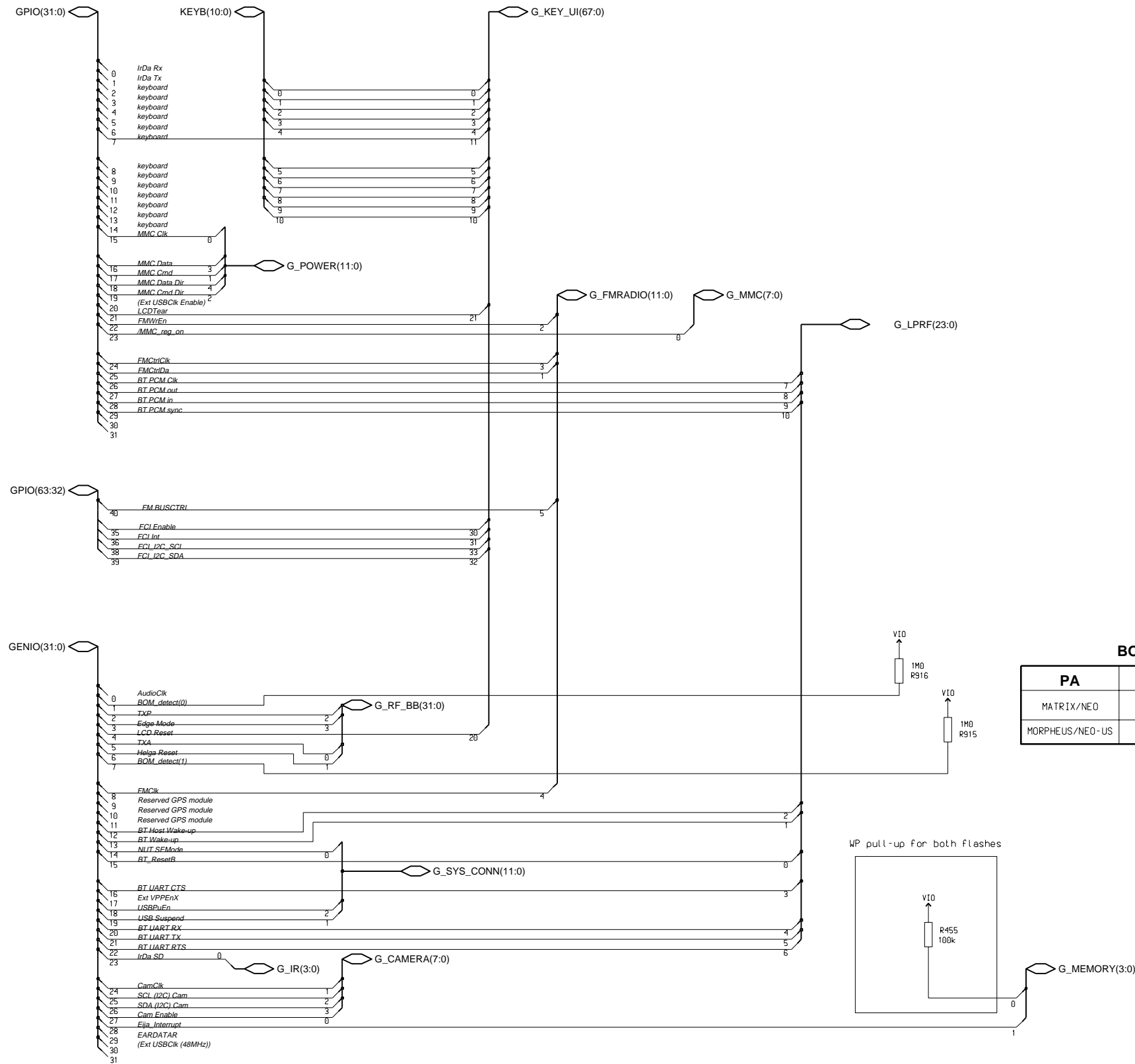

**BOM detect**

PA	R915	R916
MATRIX/NEO	Not assy	Not assy
MORPHEUS/NEO-US	Not assy	Assy